



**WB FLOOR
MACHINES**

SALES · SERVICE · HIRE



I-GUM BATTERY VERSION

USER MANUAL

CHEWING GUM REMOVAL , LI-ION BATTERY POWER

☎ 01293 852022

✉ info@wbfloormachines.co.uk

🌐 www.wbfloormachines.co.uk

🏠 Unit 7 Burns Way, Holmbush Potteries
Estate, Horsham RH12 4ST

■ **IMPORTANT SAFETY INSTRUCTIONS**
READ ALL INSTRUCTIONS BEFORE USING THIS MACHINE



Warning!

READ ALL INSTRUCTIONS
BEFORE USING THE
MACHINE



Warning!

Maintenance/service people
(not i-gum operators)
need to keep a distance to
the integrated magnets in i-gum
for 6 inch/15 cm when they are
doing maintenance on i-gum
and are wearing a pacemaker,

this is just a precaution advise



LITHIUM-ION BATTERY

Nominal Voltage:24V
Energy/Capacity: 353 Wh^r

SAFETY ADVICE

Do not crush, pierce
or damage in any way.
Do not heat or incinerate.
Do not short-circuit.
Do not dismantle.
Do not immerse in any liquids.
Only charge between
5°C~40°C/41°F~ 104°F
and discharge
5°C~45°C/41°F~113°F



■ IMPORTANT SAFETY INSTRUCTIONS

READ ALL INSTRUCTIONS BEFORE USING THIS MACHINE

DO NOT OPERATE THE MACHINE WITHOUT READING AND UNDERSTANDING THE OPERATING INSTRUCTIONS. IF THE MACHINE IS OPERATED INCORRECTLY IT CAN POSE DANGER TO THE OPERATOR AND OTHERS AND WILL INVALIDATE THE MANUFACTURERS WARRANTY. BEFORE USE, READ AND UNDERSTAND THE FOLLOWING:

1. A Risk Assessment for the works to be undertaken.
2. MSDS Chemical Data Sheet.
3. Risk Assessment for Chemical use.

IMPORTANT NOTICE:

Before inserting the batteries and gum removal solution correctly fit the machine to the operator by adjusting the straps as required. The machine's body has been designed to be kept upright at all times when the batteries are inserted to drawer and gum removal solution is in the water tank. This is important to the operation of the machine.

Cautions when using the machine:



- ✔ Keep the body upright at all times when operation or when chemical or batteries inserted.
- ✔ The rechargeable battery has been designed to be fully charged BEFORE each use
- ✔ Only use the approved solution and batteries for the safe use of the machine. Using other consumable items in the machine invalidated the warranty and will lead to damage of the internal parts of the machine and also may pose a risk to the operative.
- ✔ Make sure the operator has read and understood these instructions before attempting to use the machine and is fully trained in its operation.

Consumable Items:

Chemical (2 Litres) will last for approximately 2 hours of continual use. 4x chemical bottles will last for approximately 8 continual hour's operation.

The brushes will wear according to the surface being cleaned. Each Brush will last for approximately 4 hours. 2x Brushes will last for 8 hours continual operation. Only use the specifically designed brush as this has a jet incorporated for machine to work correctly.

Choose a steel wire brush for solid urban surface such as concrete, natural stone, tarmacadam, asphalt and other common urban surfaces. Choose a nylon brush for soft surfaces such as manmade flooring, sandstone, heavy-duty carpet.

IMPORTANT NOTICE:

Always complete a test patch on the above surfaces to make sure no damage occurs to the flooring of surface

Service Pack:

When a machine is purchased, it require a service pack. Each service pack provides a continuous 8 hours operation and consists of:

- 4x Chemical Bottles
- 1x Nylon wire Brush
- 3x Steel wire Brush

■ **Warranty:**

The Chewing Gum Removal machine should only be operated with the service packs supplied. Using alternative supplies may cause damage to the machine and cause a risk to the operative. Using alternative supplies voids manufacturer's warranty.

■ Package Check list:

When you open the color box and you can find the parts as below showing:

Machine:

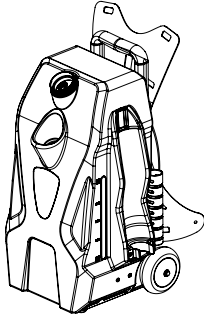

MAIN BODY 1x

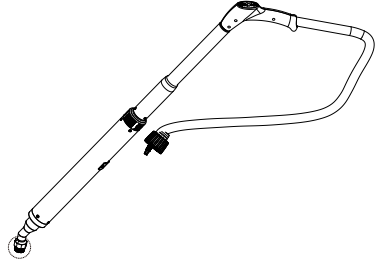

LANCE 1x + NYLON WIRE BRUSH 1x

Accessory:

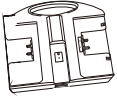

Battery Charger 1x



Power Cable

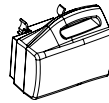

Top Battery 1x



Top Battery 1x
Bottom Battery 1x

This kit of battery & charger is packed according to the customer's order

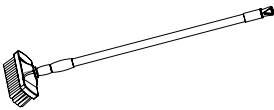

Broom with telescopic handle 1x



Nylon Wire Brush 1x



Steel Wire Brush 3x



Water Drop Disk 1x



Chemical bottles 4x



Brush Storage Tube 1x

■ Machine parts:



■ Preparation For Use

Installation1.

1. Install the water drop disk to body.

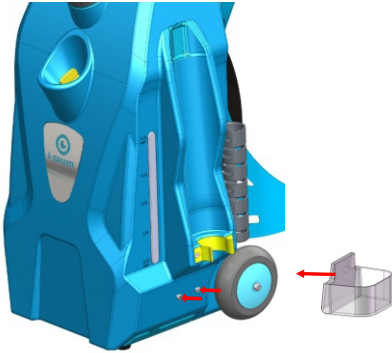

2. Screw a steel wire or nylon wire brush onto the end of the nozzle of the lance.



3. Place the lance in the lance holder of body. There are 2 magnets which hold the lance in position.
(The lance needs to be removed before the machine is fitted to the operative.)



4. Open the brush storage tube cap and you can place the brushes in the tube.
Insert the brush storage tube to the holder of body.



5. Assembly the brush to telescopic wand for the BROOM.

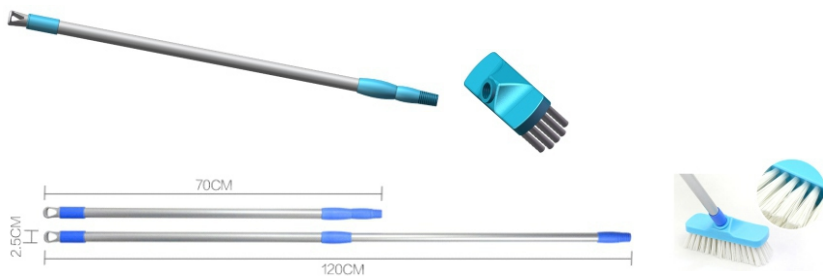

6. Insert the broom to broom holder of body.
(The Broom needs to be removed before the machine is fitted to the operative.)

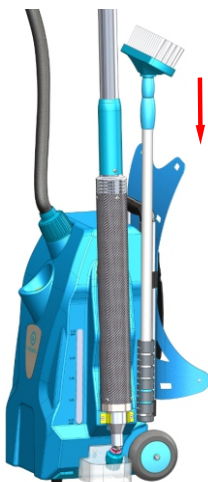

■ Preparation For Use Installation 2

Before operating the machine:

1. Ensure that the battery has been fully charged before each operation.
Before you charge the battery, please read the INSTRUCTION MANUAL OF BATTERY CHARGER first. The manual is in the package of the charger box. please keep the manual.

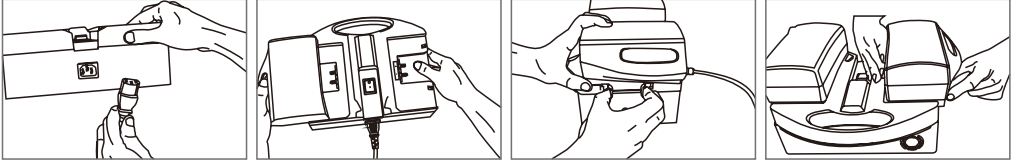

2. Pour solution into fluid tank.



Take off the fluid inlet cap and then pour solution into the fluid tank. (one bottle is for each time).

3. Insert Batteries

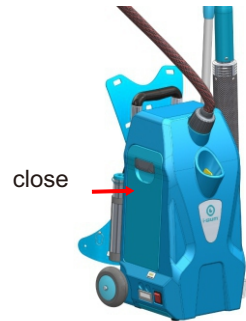
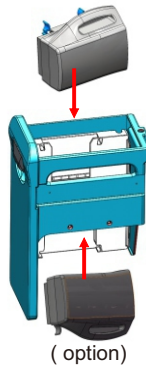

Open the battery storage drawer and install the batteries to the battery housing.
Then push the storage drawer back (must be pushed into location).

(You also can install one battery, the machine also can work.)

■ Preparation For Use

INSTRUCTION FOR CONTROL PANEL

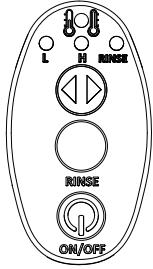

ON/OFF Button: Power supply for handle control.



RINSE Button, In **FIRST** use, press the RINSE button for about 1 minute to pour fluid into boiler to avoid boiler heating up without fluid.
In **NORMAL** use, we do not need to press this button for 1 minute, because the fluid will flow to boiler from pipe after few seconds.
(The LED light will flush when we press the RINSE button)



H/L Button, Adjust the fluid flowing in low speed or high speed.
(Flowing speed indicator light will be bright, and the heating LED will flush)



Rinse indicator light



Flowing speed indicator light



Heating indicator light

INSTRUCTION FOR BODY CONTROL PANEL



Timer for machine using 9999H59M59S

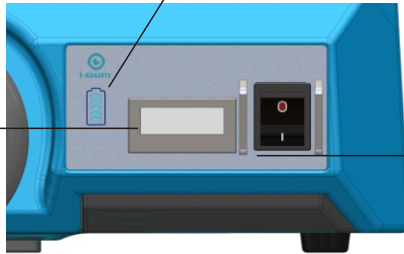

Battery Power Indicator



Main Switch For Power Supply

INSTRUCTION FOR WATER LEVEL INDICATOR

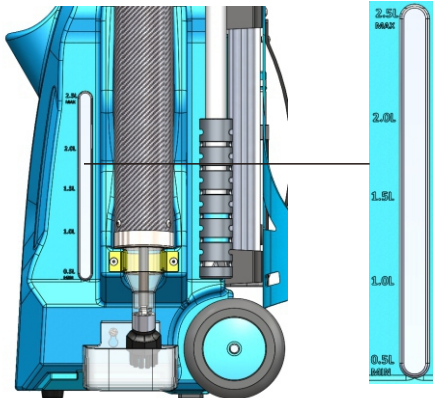

The fluid tank capacity is 2.5L. Each use, we can input one chemical bottle into the tank. When low on fluid, the LED light of tank side will flash and the heater in lance will stop working and the heater indicator will flash.

When you pour Chemical into fluid tank, And then restart the main switch of body, the LED light will be bright, and press on/off button on handle, the heater will start to heat.

■ Using the machine:

LOGIC FOR FIRST TIME OPERATION (Just for the *first using*)



Turn on the Mainswitch on body



Turn on ON/OFF button on lance control panel



Press RINSE button on lance control panel



RISEN INDICATOR LIGHT flash, and pump will run in full speed.

After about 1 minute, the fluid come out from brush of lance



Release RINSE button on lance control panel



Fluid in boiler will start to heat up and the heating indicator will flash, the pump will automatically switch over to the low speed.

***After about 20 seconds, fluid will be heated to steam,
and the steam will come out from brush of lance***



The steam will come out from the hole of brush, and the heating indicator will be bright. After few seconds, the steam temperature will be raised.



Change the L/H selector button for pump speed,
And you can get less/more steam.



Place the brush on the piece of flattened gum, Agitate the flattened gum with the brush until you see it disintegrate by using circular motions-do not scrub or apply pressure. The weight of the lance with agitation is all that is required.

Remove the lance from the gum and use a broom to sweep across the area to ensure the gum has been destroyed or if further cleaning is needed.

As gum deposits are all different there will be varying times taken to destroy each piece.

■ Using the machine:

LOGIC FOR NORMAL USE *(DO NOT press Rinse button to wait for 1 minute)*



Turn on the Main switch on body



Turn on ON/OFF button on lance control panel



Fluid in boiler will start to heat and heating indicator light will flush. And pump will automatic switch-over to low speed



After about 20 seconds, the fluid will be heated to steam and steam will come out from brush of lance



The steam will come out from the hole of brush, and the heating indicator will be bright. After few seconds, the steam temperature will be raised.



Change the L/H selector button for pump speed. And you can get less/more steam.





Place the brush on the piece of flattened gum, Agitate the flattened gum with the brush until you see it disintegrate by using circular motions-do not scrub or apply pressure. The weight of the lance with agitation is all that is required.

Remove the lance from the gum and use a broom to sweep across the area to ensure the gum has been destroyed or if further cleaning is needed.

As gum deposits are all different there will be varying times taken to destroy each piece.

Turning OFF the machine:

- 1  Turn off ON/OFF button on lance control panel.
- 2  Turn off the Main switch on the body.
- 3  Open the drawer and take out the batteries from battery housing.

- 4  Charge for batteries.

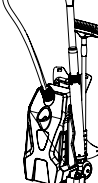
- 5  Place the lance to holder of body. Insert the broom to broom holder of body.

■ Maintenance

Machine maintenance

The BATTERY VERSION I-GUM machine requires very little maintenance. Wipe down the machine periodically with a clean cloth. And wipe down the lance, and change the new brush for the lance. DO NOT spray water directly over the top of machine or top connector cap.



1. During interruptions of the cleaning process, always place the lance into the holder of body. And always place the machine upright on dry floor surface.



2. When the water drop disk is full, please empty and wash it, and then install back to body.



3. The yellow rubber bung must be pushed to the inlet hole, when you finish the fluid input. Otherwise dirt will infect the water tank.



DO NOT put any other fluid into the tank unless approved by the manufacturer.



4. Make sure the batteries are charged 100% on the first charge.



5. The top cap for hose connector is assembled by the factory, DO NOT disassemble the hose connector cap unless qualified.

The connectors are showed as the picture:

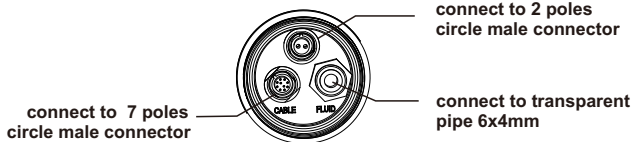

■ PRODUCT SPECIFICATION

battery version i-gum

Product Size (body unit):	347*330*500 mm
Lance Size:	60*1100 mm
Weight (Included 1x battery):	10.5 kg
Lance Weight:	1.6 kg
Broom Extended Length:	1.3 M
Li-ion Battery:	DC24V (25.2V,14Ah, 353Wh ^{*)})
Tank Capacity:	2.5 L
Battery Drawer :	Can install 2x Batteries
Operation Time of Battery :	About 50 min/ 1 Battery
Fluid Flow Speed Class:	Low, High
Control Panel in Handle:	YES
Trolley Handle:	YES
Transport Wheel:	YES
Backpack For Body Unit:	YES
Water Shortage Warning:	YES
Fluid Heater:	DC 24V, 250W

