

EN, DE, FR, NL, PT, IT,  
ES, PL, SV, FI, DA

# WBV370NX WBV470NX

Kit A11/85

# Numatic

numatic.com

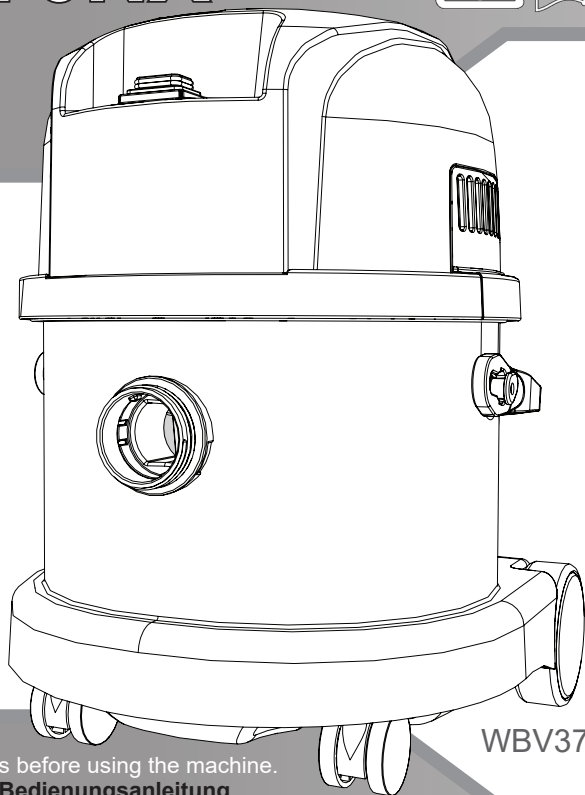

WBV370NX

## Original Instructions

CAUTION, Read instructions before using the machine.

## Übersetzung der Original-Bedienungsanleitung

VORSICHT, Vor Verwendung der Maschine bitte die Anleitung lesen.

## Traduction du manuel d'utilisation d'origine

AVERTISSEMENT, Lisez la notice avant d'utiliser la machine.

## Vertaling van de oorspronkelijke gebruiksaanwijzing

LET OP, Lees deze gebruiksaanwijzing voordat u de machine gebruikt.

## Tradução das Instruções Originais

CUIDADO, Leia as instruções antes de usar a máquina.

## Traduzione del manuale d'uso originale

ATTENZIONE, Leggere le istruzioni prima di utilizzare l'apparecchio.

## Traducción del manual de uso original

PRECAUCIÓN, Lea las instrucciones antes de utilizar la máquina

## Tłumaczenie oryginalnej instrukcji obsługi

PRZESTROGA, Przed przystąpieniem do używania maszyny należy zapoznać się z niniejszą instrukcją.

## Översättning av den ursprungliga användarhandboken

VARNING, Läs anvisningarna innan du använder maskinen.

## Alkuperäisen käyttöohjeen käännös

HUOMIO, Lue ohjeet ennen koneen käyttöä.

## Original vejledning

Advarsel! Læs vejledningen inden brug af maskinen



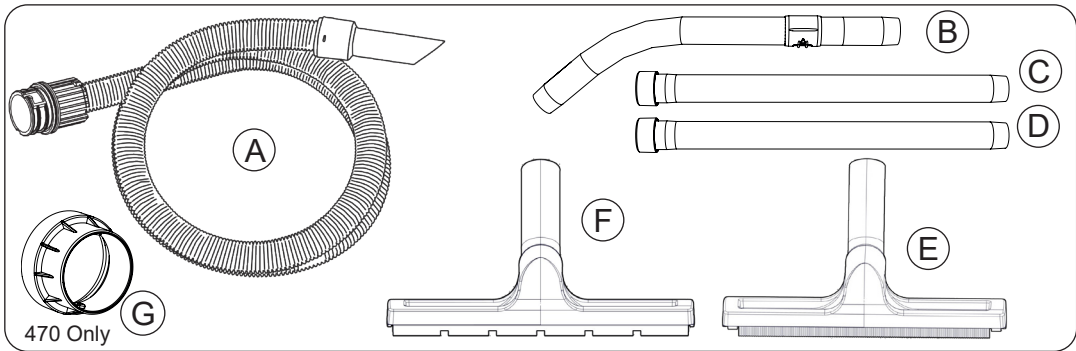

- NX300 Battery Fitting** • NX300 – Akkuanschluss • Fixation de la batterie NX300  
 • NX300 accu plaatsen • NX300 Fixação da bateria • Inserimento batteria NX300  
 • Colocación de la batería NX300 • NX300 — montáž akumulátora  
 • NX300 – montera batteriet • NX300-akun asennus  
 • NX300 – Batterifitting

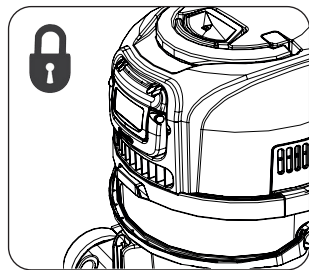
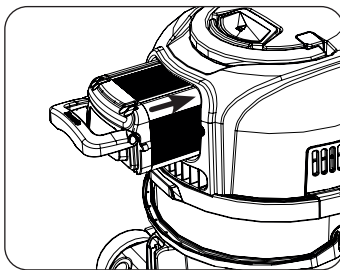
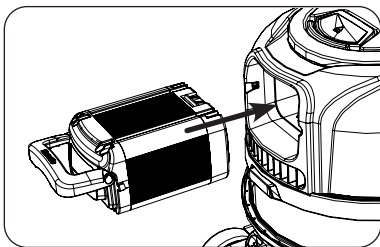

- Wet - Assembling the machine for use** • Nass – Zusammenbau des Geräts vor Gebrauch  
 • Humide - Montage de la machine pour l'utilisation • Nat - De machine monteren voor gebruik  
 • A húmido – Montar a máquina para utilização • Umido - Assemblaggio dell'apparecchio per l'uso  
 • Húmedo: montaje de la máquina para su uso • Czyszczenie na mokro — montaż urządzenia  
 • Våt användning – montera maskinen för användning • Märkä – Koneen käyttöönotto  
 • Våd – Montering af maskinen til brug

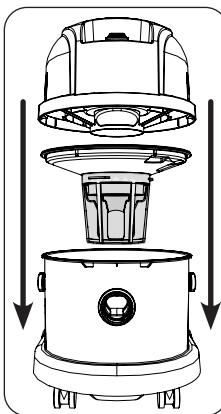

- Wet Use  
 Nasseinsatz  
 Utilisation humide  
 Nat gebruik  
 Utilização a húmido  
 Uso da umido  
 Uso en húmedo  
 Czyszczenie na mokro  
 Våt användning  
 Märkäkäyttö  
 Våd brug

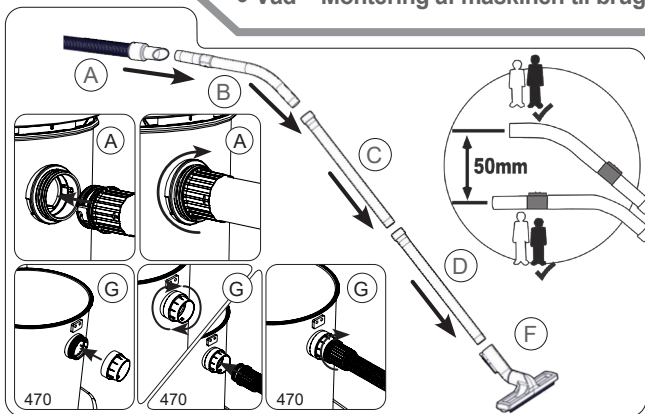

Wet - Emptying your machine • Nass – Entleeren des Geräts

- Humide - Vidage de votre machine • Nat - De machine legen • A húmido – Esvaziar a máquina
- Umido - Svuoatamento dell'apparecchio • Húmedo: vaciado de la máquina
- Czyszczenie na mokro — opróżnianie urządzenia • Våtänvändning – tömma maskinen
- Märkä – Koneen tyhjennys • Våd – Tømning af maskinen

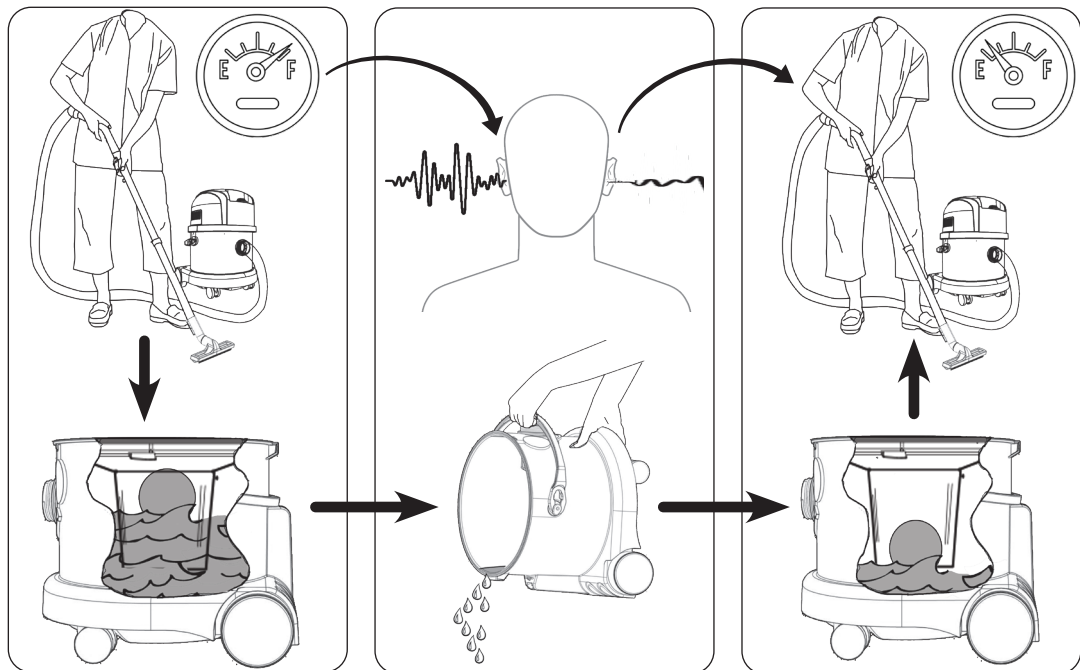

- Wet - Using the machine • Nass - Gebrauch des Geräts • Humide - Utilisation de la machine
- Nat - De machine gebruiken • A húmido - Utilizar a máquina • Umido - Uso dell'apparecchio
  - Húmedo: utilización de la máquina • Czyszczenie na mokro - eksploatacja urządzenia
  - Våtänvändning – använda maskinen • Märkä – Koneen käyttö
  - Våd - Brug af maskinen

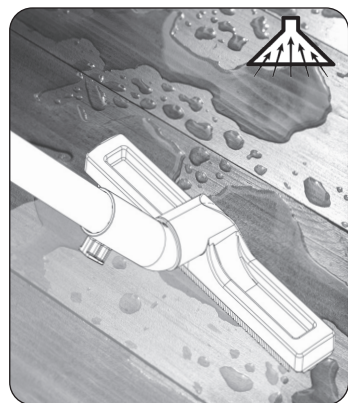
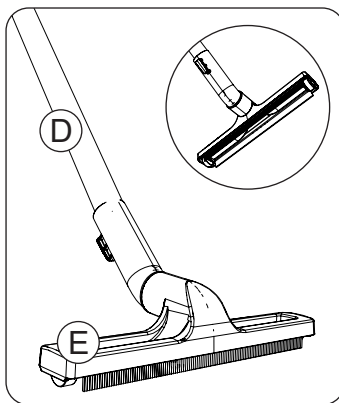
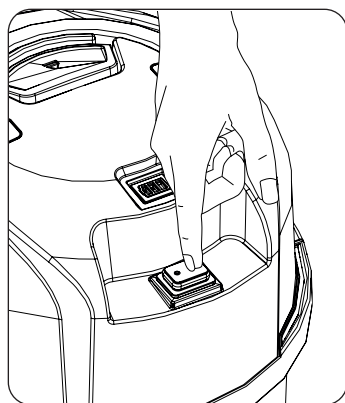

Cleaning your machine • Reinigung des Geräts • Nettoyage de votre machine  
 • De machine reinigen • Limpar a máquina • Pulizia dell'apparecchio  
 • Limpieza de la máquina • Czyszczenie urządzenia  
 • Rengöra maskinen • Koneen puhdistus  
 • Rengøring af maskinen

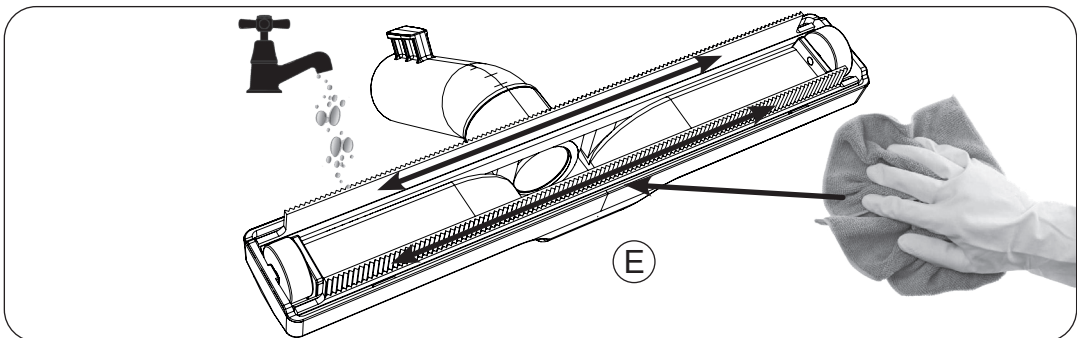
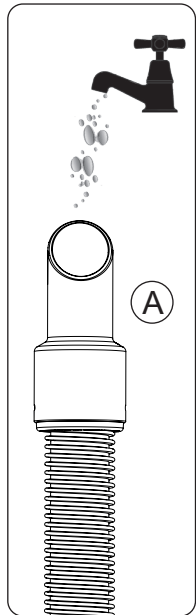
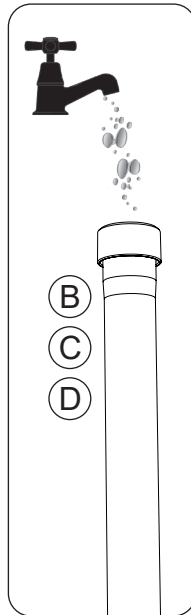
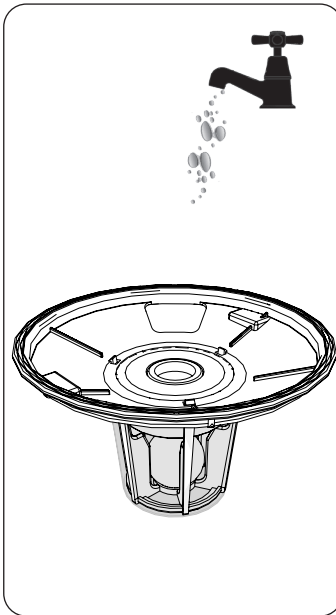
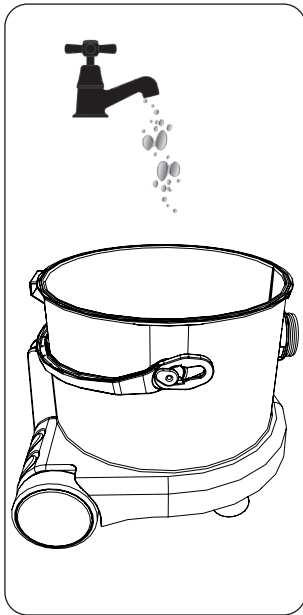
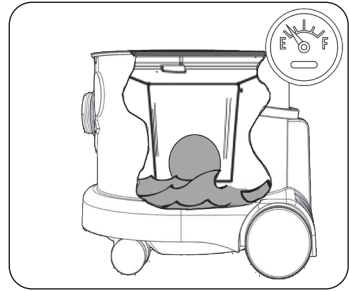
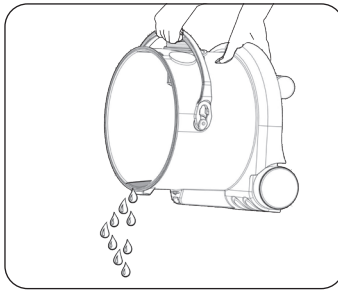
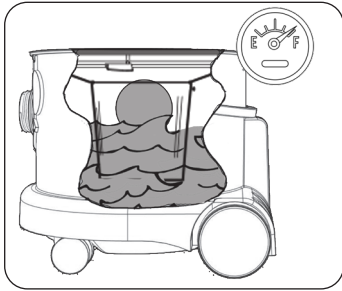

- Dry - Assembling the machine for use • Trocken – Zusammenbau des Geräts vor Gebrauch
- Sec - Montage de la machine pour l'utilisation • Droog - De machine monteren voor gebruik
  - A seco – Montar a máquina para utilização • Secco - Assemblaggio dell'apparecchio per l'uso
  - Seco: montaje de la máquina para su uso • Czyszczenie na sucho — montaż urządzenia
  - Torrvändning – montera maskinen för användning • Kuiva – Koneen käyttöönotto
  - Tør – Montering af maskinen til brug

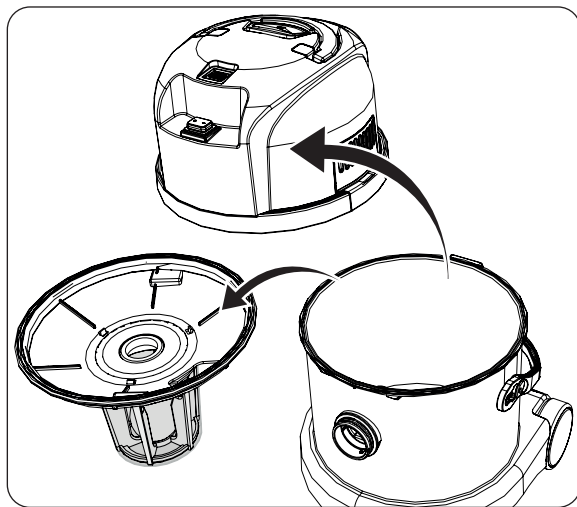

Dry Use  
Trockeneinsatz  
Utilisation à sec  
Droog gebruik  
Utilização a seco  
Usò a secco  
Usò en seco  
Czyszczenie na sucho  
Torrvändning  
Kuivakäyttö  
Tør brug

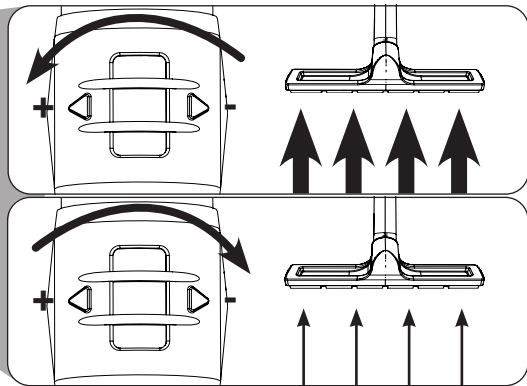
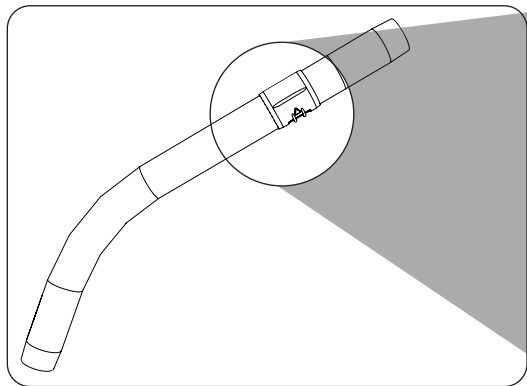
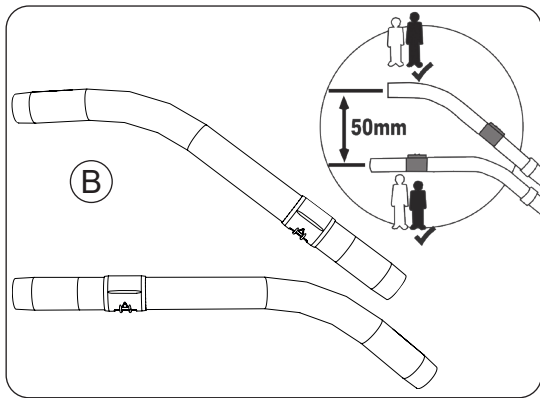
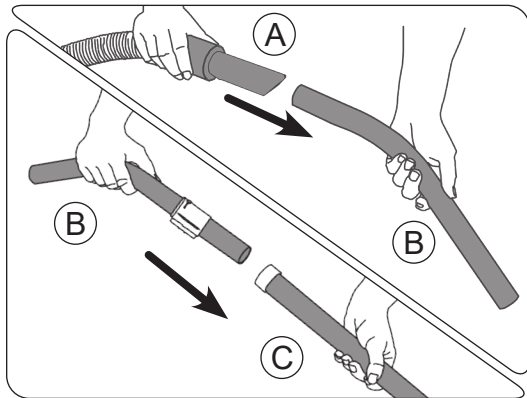
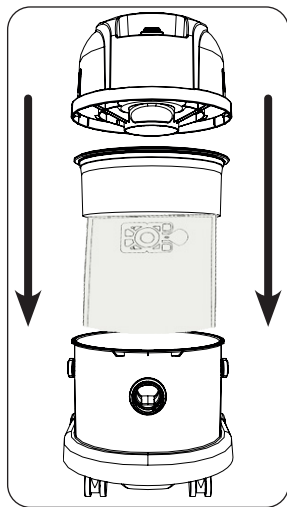

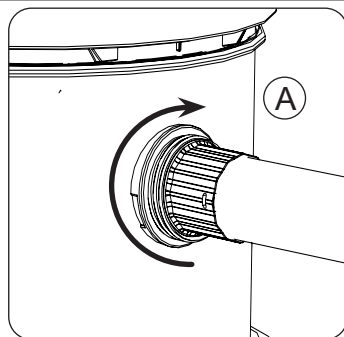
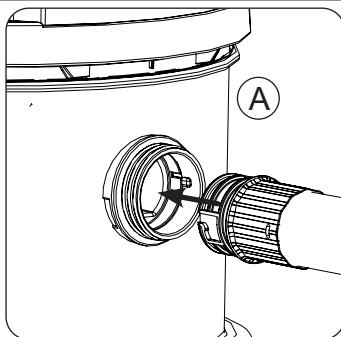
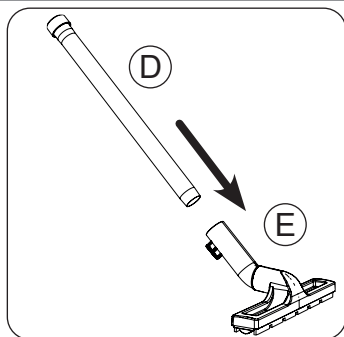

- Dry - Using the machine • Trocken - Gebrauch des Geräts • Sec - Utilisation de la machine**  
**• Droog - De machine gebruiken • A seco - Utilizar a máquina • Secco - Uso dell'apparecchio**  
**• Seco: utilización de la máquina • Czyszczenie na sucho - eksploatacja urządzenia**  
**• Torrvändning - använda maskinen • Kuiva - Koneen käyttö**  
**• Tør - Brug af maskinen**

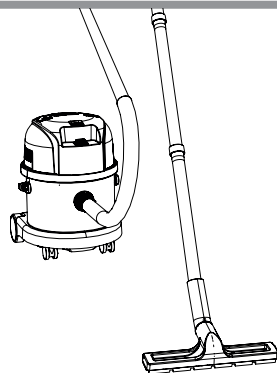
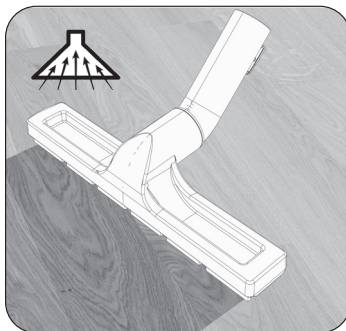
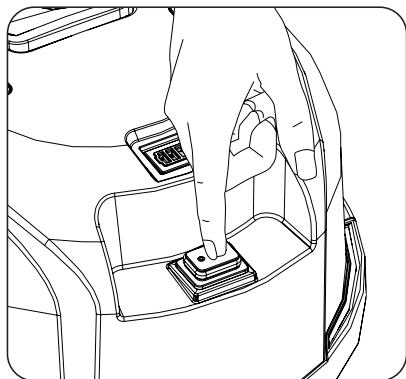

**WBV470NX**

- 470 Handle • Handhaben • Poignée • Hendel • Lidar • Maniglia**  
**• Manejar • Uchwył • Hantera • Kahva • Håndtere**

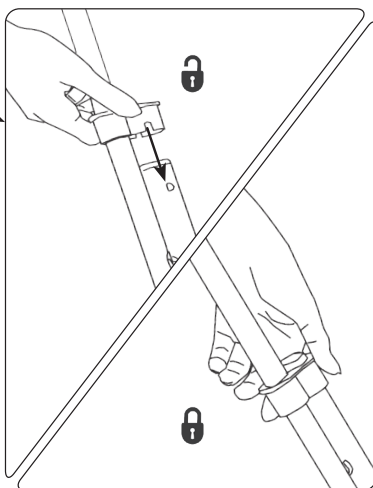
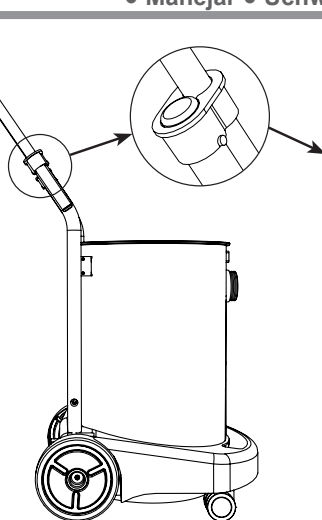
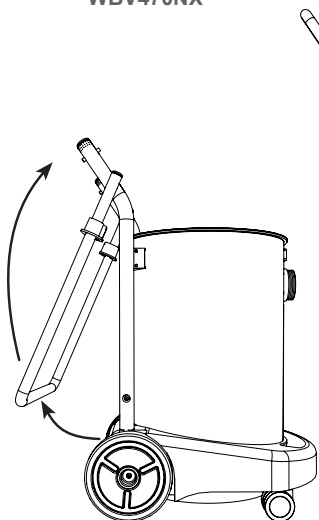

**Dry - Emptying your Hepa Flo Bag • Trocken – Entleeren des HEPA-Flo-Beutels**

• Sec - Vidage de votre sac Hepa Flo • Droog - De Hepa Flo-zak legen

• A seco – Esvaziar o saco Hepa Flo • A secco - Svotamento del sacchetto Hepa Flo

• Seco: vaciado de la bolsa HEPA Flo • Czyszczenie na sucho — opróżnianie worka HEPA Flo

• Torranvändning - tömma HEPA Flo-påsen • Kuiva – Hepa Flo Bag -pussin tyhjentäminen

• Tør – Tømning af din Hepa Flo-pose

Dry Use - Trockeneinsatz - Utilisation à sec -

Droog gebruik - Utilização a seco - Uso a secco -

Uso en seco - Czyszczenie na sucho - Torranvändning -

Kuivakäyttö - Tør brug

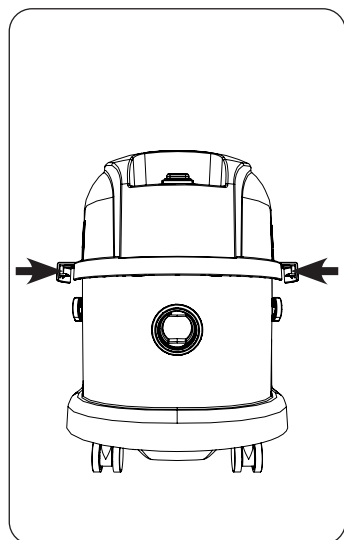
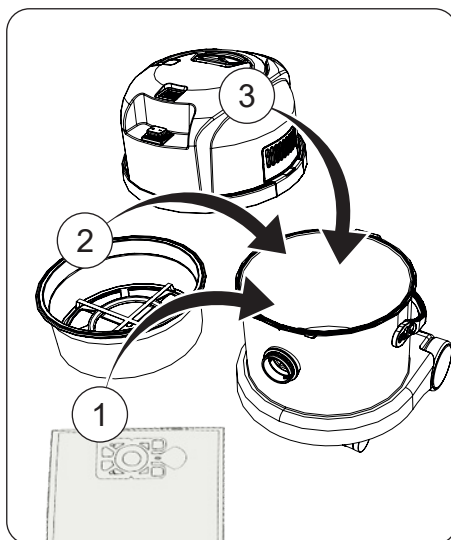
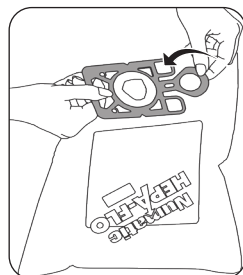
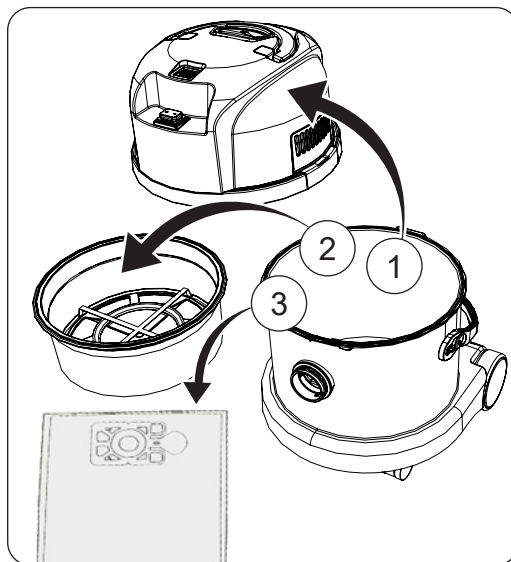
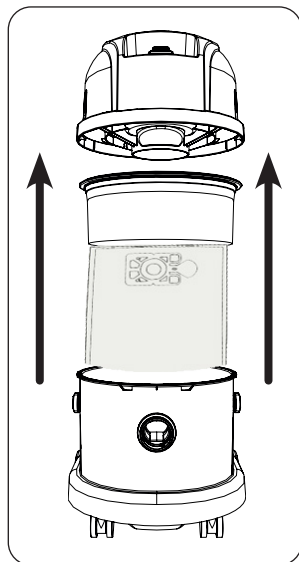

Floor Tool Tidy • Abstreifer in Ordnung • Rangement du suceur • Schoon vloerelement  
• Arrumação da ferramenta do pavimento • Pulizia del tergilpavimento  
• Limpieza de la boquilla de aspiración • Czyszczenie z użyciem ssawki do podłóg  
• Golvmunstycket Tidy • Lattiatyökälyn säilytyspussi  
• Tidy-gulvuhed

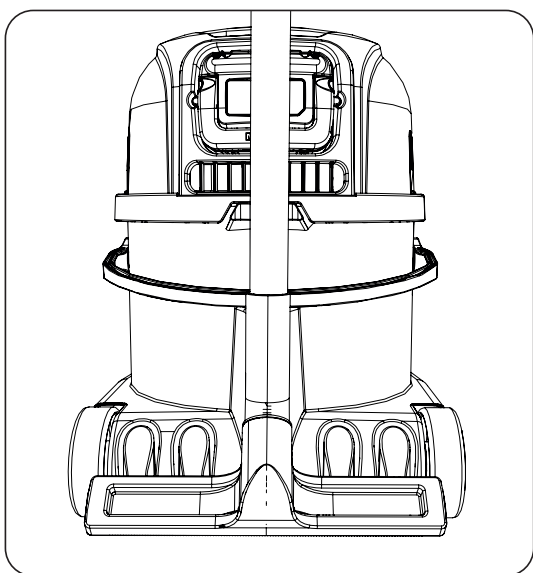
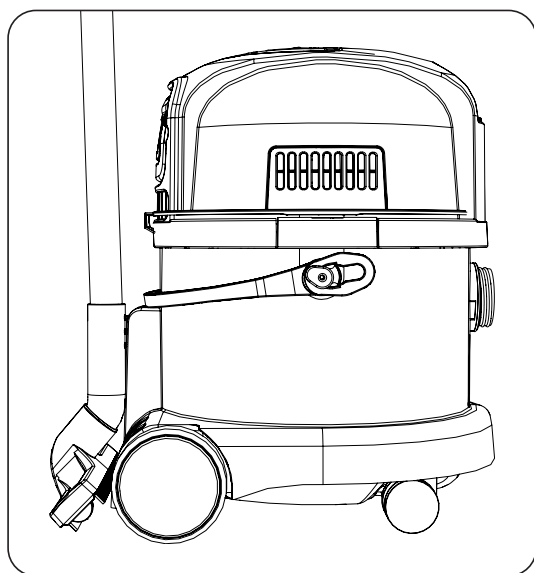
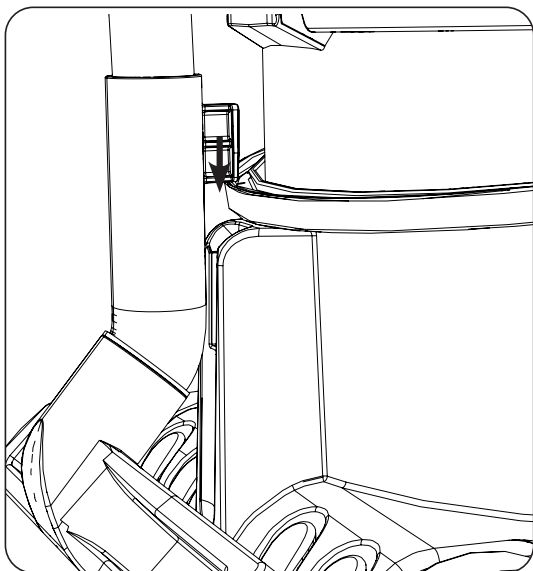
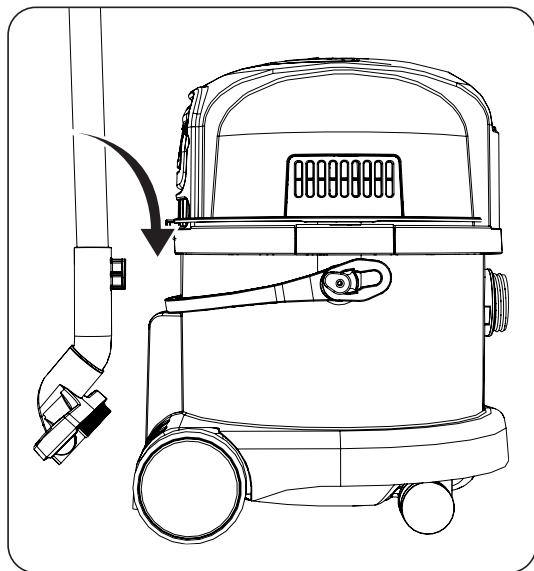

**Battery Status • Akkuladestand • État de la batterie • Accustatus • Estado da bateria**  
**• Stato della batteria • Estado de la batería • Stan akumulatora • Batteristatus • Akun tila**  
**• Batteristatus**

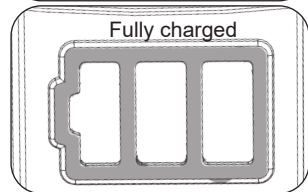
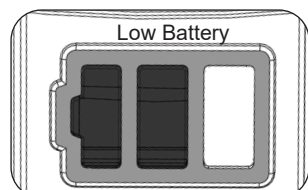
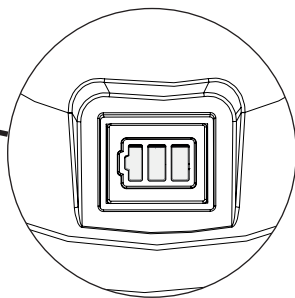
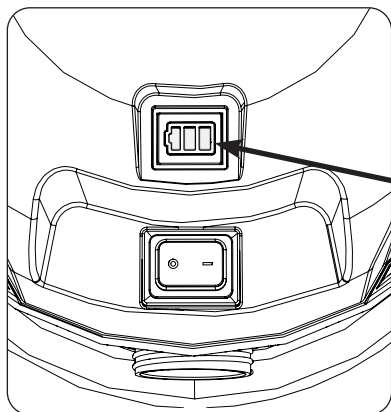

**Charging your battery • Laden des Akkus • Chargement de votre batterie • De accu opladen**  
**• Carregar a bateria • Ricarica della batteria • Carga de la batería • Ładowanie akumulatora**  
**• Ladda batteriet • Akun lataaminen • Opladning af batteriet**

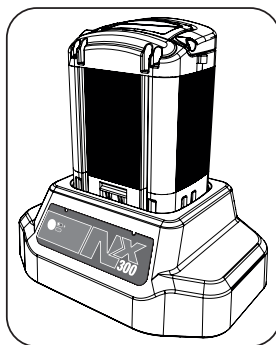
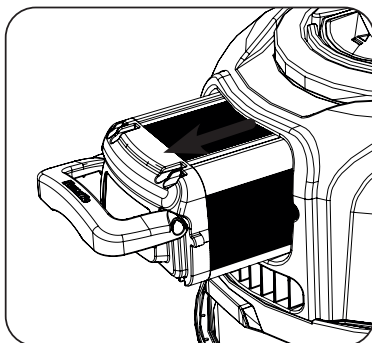
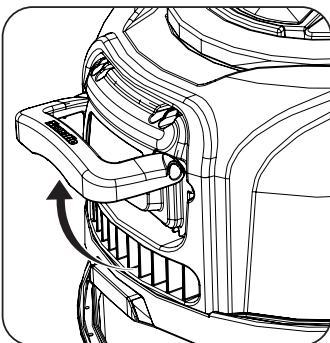
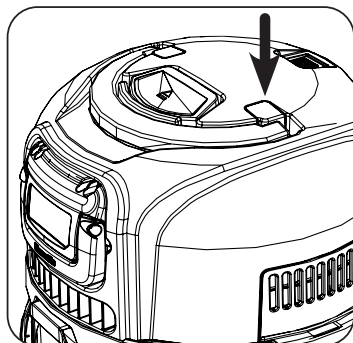

EN - For information relating to the operation and charging of your battery refer to the battery and charger original operating instructions.  
 DE - Informationen zum Betrieb und zum Laden Ihres Akkus entnehmen Sie bitte der Originalbetriebsanleitung des Akkus und des Ladegeräts.  
 FR - Pour toute information concernant le fonctionnement et la recharge de votre batterie, voir le mode d'emploi d'origine de la batterie et du chargeur.  
 NL - Zie voor meer informatie over de bediening en het opladen van de accu de originele bedieningshandleiding van de accu en de oplader.  
 PT - Para obter informações sobre o funcionamento e o carregamento da bateria, consulte as instruções originais de funcionamento da bateria e do carregador.  
 IT - Per informazioni su intervento e ricarica batteria, vedi istruzioni originarie su batteria e caricabatteria.  
 ES - Para obtener información sobre el funcionamiento y la carga de la batería, consulte el manual de instrucciones original de la batería y del cargador.

PL - Informacje dotyczące obsługi i ładowania akumulatora można znaleźć w oryginalnych instrukcjach obsługi akumulatora i ładowarki.

SV - Information om hur du använder och laddar batteriet finns i bruksanvisningen till batteriet och laddaren.

FI - Katso akun käyttöä ja latausta koskevat ohjeet akun ja laturin alkuperäisistä käyttöohjeista.

DA - Se den originale betjeningsvejledning til batteriet og opladeren for at få oplysninger om betjening og opladning af batteriet.

## Rating Label

1	Voltage / Direct Current
2	Rated input power
3	Weight (ready to work)
4	Company name & address
5	Model
6	Machine yr/wk Serial number
7	Approval Mark
8	WEEE Logo
9	Use Lithium-Ion Battery Only
10	IPX Rating

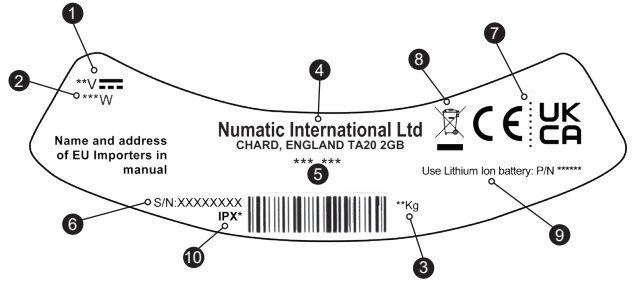

## WEEE Legislation (Waste, Electrical and Electronic Equipment)

Vacuum cleaner, accessories and packaging should be sorted for environmentally - friendly recycling.

**(Only for UK & EU Countries)** Do not dispose of vacuum cleaner into household waste! According to the European Directive 2012/19/EU on waste electrical and electronic equipment and its incorporation into national law.

Vacuum cleaners that are no longer suitable for use must be separately collected and sent for recovery in an environmentally - friendly manner.



**PPE (personal protective equipment)** That may be required for certain operations.

Ear Protection	Safety Footwear	Head Protection	Safety Gloves	
Eye Protection	Protective Clothing	Dust / Allergens Protection	Hi Viz Jacket	

**Note:** A risk assessment should be conducted to determine which PPE should be worn.

Failure to rectify the problem or in the event of a breakdown contact your Numatic dealer or the Numatic Technical helpline +44 (0)1460 269268

### Daily

- Keep the machine clean, including hoses and tubes.
- Ensure the bag and filter are fitted.
- Regularly examine the charger.
- Check dust bag frequently.
- Check filters are clean.

### Weekly - as daily and:-

- Check for any worn or damaged parts and replace immediately.
- Do not steam clean or pressure wash.

### Batteries

- Always recharge the batteries after use.

MAINTENANCE

## Safety Critical Components

Multi-Regional Charger 911334 (100-240V ~ 50/60 Hz)

Lithium- Ion Battery 8.1 Ah

# Information for WET & DRY use Battery Vacuum Cleaners

## Warning

Read the instruction manual before using the machine.

Operators shall be adequately instructed on the use of these machines.

As with all electrical equipment, care and attention must be exercised at all times during use, in addition to ensuring that routine and preventative maintenance is carried out periodically to ensure safe operation.

Failure to carry out maintenance as necessary, including the replacement of parts to the correct standard could render this equipment unsafe and the manufacturer can accept no responsibility in this respect.

The machine shall be switched off and the battery removed before cleaning or maintenance and when replacing parts or converting the machine to another function.

This machine is not to be used by children or persons with reduced physical, sensory or mental capabilities, or lack of experience or knowledge.

Children being supervised are NOT to play with the machine. This appliance is intended to be assembled, cleaned and maintained by an adult. This machine is not a toy. This machine is not suitable for picking up hazardous or explosive dust. Contact your local distributor if you require a machine capable of performing these tasks.

## Caution

If foam/liquid comes out of machine exhaust, switch off immediately.

Allow the accumulated liquid to drain out through the machine exhaust, check the float assembly to ensure correct operation, empty the container if full of liquid, reassemble the machine.

Immediately upon start up there will be a certain amount of liquid issuing from the machine exhaust which will be the residue of liquid still within the power head. This will be quickly discharged after which the machine should function normally.

Liquid ejected from the machine could be hazardous as a result of its temperature, pressure or chemical content.

Ensure that the filtration system fitted to the machine is suitable for the material being collected.

This machine is for indoor use only. This machine shall be stored indoors only.

When moving from one place to another, consider the weight of the machine.

## Notes

This product complies with the requirements of clause 20 of IEC/EN 60335-2-69 Stability and Mechanical Hazards.

The primary use for this machine is commercial, for example in hotels, schools, hospitals, factories, shops and offices.

If the vacuum cleaner stops working, remove the battery before investigating where the fault lies.

The vacuum cleaner should be inspected after use for damage.

## Do

- Use a bag and filter at all times when using 'dry'.
- Keep your machine clean.
- Keep filters clean.
- Regularly clean the water level limiting float safety valve and examine for signs of damage or correct operation.
- Keep hoses and tubes clear.
- Replace any worn or damaged parts immediately.
- Wet filters and the interior part of the liquid container shall be dried before storage.

## Don't

- Use steam cleaners or pressure washers to clean the machine or use the machine in the rain.
- Immerse in water for cleaning.
- Allow any inexperienced repairs. Call the experts.
- Use wet if float valve is not functioning or fitted.
- Use to suck up hot ashes, or lighted cigarette ends.
- Walk over-wet carpets, upholstery or fabrics.
- Walk on clean carpets until fully dry.
- Attempt machine maintenance or cleaning unless the battery has been removed from the machine head.
- Under any circumstances place foreign objects including (but not limited to) air fresheners, air freshener capsules or scented beads of any type into the top filter of the machine. Doing so can be dangerous and risk damage to the machine and may invalidate the machine warranty.

## Fault Finding

### Dry Mode maintenance/fault finding

If the vacuum cleaner stops working switch off and remove the battery before investigating were the fault lies.

If the vacuum cleaner will not pick up any debris from the surface, switch off and remove the battery, inspect the floor tool, wands and hose for blockages, if no blockages are found, the dust bag may be full if the dust bag is not full the filter may be blocked.

### Wet mode

If the vacuum cleaner stops working switch off and remove the battery before investigating were the fault lies.

If the vacuum cleaner has a blockage and will not pick up liquid, switch off and remove the battery. Has the float valve operated?, this will shut off the suction and the pitch of the vacuum motor will change.

Remove the power head and empty the liquid out of the container, if the container is empty, check that the floor tool wands and hose are not blocked.

Flush the system with clean water after use.

After use always inspect the machine for damage.