

**Duplex OPC 340, 420, 620**  
**USER AND MAINTENANCE GUIDE**

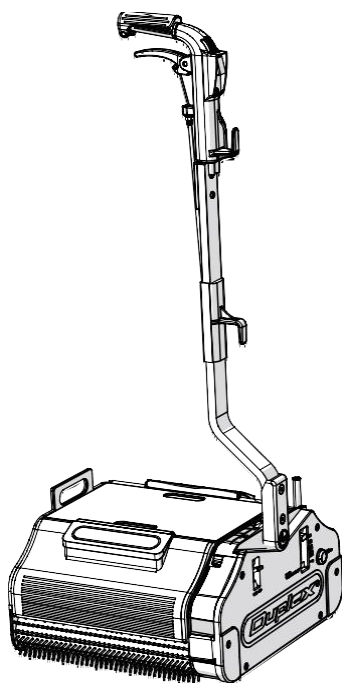

**STANDARD**

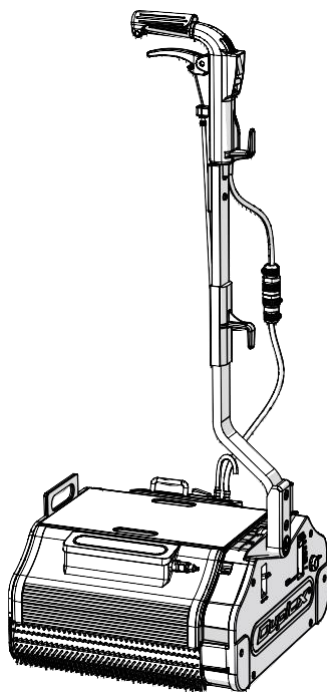

**STEAM**

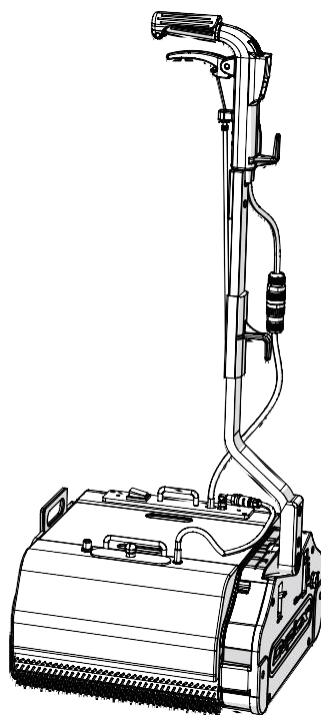

**STEAM PLUS**



**340 / 420 / 620**



***DUPLEX 340 / 420 / 620***  
***FLOOR CLEANER - CARPET CLEANER***



## Table of Contents

EN

<b>1. PURPOSE AND CONTENT OF THE MANUAL</b>	<b>6</b>
1.1 SYMBOLS	6
1.2 PURPOSE OF THE MANUAL	6
1.3 CONSERVATION	7
1.4 UPDATING THE MANUAL	7
1.5 CONFIDENTIALITY	7
1.6 RECIPIENTS	7
<b>2. GENERAL INFORMATION</b>	<b>8</b>
2.1 MANUFACTURER IDENTIFICATION DATA	8
2.2 LIABILITY LIMITATIONS	8
2.3 IDENTIFICATION PLATE	9
2.4 REFERENCE STANDARDS AND CONFORMITY	10
2.4.1 DECLARATION OF CONFORMITY	11
2.5 WARRANTY	12
<b>3. GENERAL SAFETY INSTRUCTIONS</b>	<b>14</b>
3.1 RESIDUAL RISKS	14
3.2 GENERAL REQUIREMENTS	15
3.3 ELECTRICAL HAZARDS	16
3.3.1 POWER CORD	16
3.4 SAFETY SIGNS	18
3.5 NOISE LEVEL	19
3.6 VIBRATION LEVEL	19
<b>4. TECHNICAL CHARACTERISTICS</b>	<b>20</b>
4.1 GENERAL DESCRIPTION	20
4.1.1 PROPER AND IMPROPER USE	20
4.2 DESCRIPTION OF THE COMPONENTS	21
4.2.1 TECHNICAL SPECIFICATIONS	23
4.3 TYPE OF DETERGENTS	25
<b>5. ASSEMBLING THE APPLIANCE</b>	<b>26</b>

<b>5.1</b>	<b>PACKING CONTENTS .....</b>	<b>27</b>
<b>5.2</b>	<b>ASSEMBLING THE HANDLE .....</b>	<b>30</b>
5.2.1	ASSEMBLING THE HANDLE - TEKNA MODEL.....	32
5.2.2	DISASSEMBLING THE HANDLE .....	33
<b>6.</b>	<b>OPERATION AND USE _____</b>	<b>34</b>
6.1	FILLING THE APPLIANCE WITH THE WASHING LIQUID.	34
6.2	STARTING THE APPLIANCE .....	35
6.3	OPERATING PROCEDURE FOR ALL MODELS.....	36
6.4	HOW TO WASH FLOORS .....	37
6.4.1	STAGE 1 .....	37
6.4.2	STAGE 2 .....	37
6.5	FOREWORD: STEAM AND STEAM PLUS .....	38
6.5.1	STEAM KIT OPERATION .....	38
6.5.2	USING THE STEAM AND STEAM PLUS MODELS.....	39
6.5.3	USING ABS DETERGENT TANKS ON STEAM AND STEAM PLUS MODELS.....	40
6.6	FLOOR CLEANING TIPS .....	41
6.6.1	CLEANING EXTREMELY DIRTY FLOORS .....	41
6.6.2	CLEANING CARPETS AND RUGS.....	42
6.6.3	CLEANING WOODEN FLOORS .....	42
6.6.4	USING WAX CLEANERS .....	42
6.6.5	POLISHING FLOORS USING LIQUID WAX.....	43
6.7	STOPPING THE APPLIANCE.....	44
6.8	TRANSPORT .....	45
6.8.1	TRANSPORT TROLLEY .....	45
6.9	AUTOMATIC MOTOR PROTECTION "MOTOR PROTECTOR".....	46
<b>7.</b>	<b>MAINTENANCE _____</b>	<b>47</b>
7.1	CLEANING.....	47
7.1.1	CLEANING THE DRIP CHANNELS .....	49
7.2	BRUSH MAINTENANCE .....	50
7.2.1	REPLACING THE BRUSHES .....	51
7.2.2	CLEANING THE BRUSHES .....	51
7.3	REPLACING THE SCRAPERS.....	52



7.4 CONVEYORS ..... 52

7.5 DESCALING (STEAM / STEAM PLUS MODELS) ..... 53

7.6 CLEANING AND REPLACING THE FILTER (STEAM / STEAM PLUS MODELS) ..... 53

7.7 POWER CORD ..... 54

7.8 ROUTINE MAINTENANCE TABLE ..... 55

7.9 DISPOSAL ..... 56

    7.9.1 DIFFERENTIATION AND SORTING OF THE MATERIALS ..... 56

**8. TROUBLESHOOTING \_\_\_\_\_ 57**

Page intentionally left blank

# 1. PURPOSE AND CONTENT OF THE MANUAL

## 1.1 SYMBOLS

To ensure the safety of persons and property, this manual contains special symbols which draw attention to particularly dangerous situations, warnings and important information:

**HAZARD!**

Hazard with a risk of injury or even death.

Accident prevention regulations for the operator.

PAY THE UTMOST ATTENTION TO TEXT BLOCKS INDICATED BY THIS SYMBOL.

**ELECTRICAL HAZARD!**

Hazard with a risk of injury or even death.

Accident prevention regulations for the operator.

PAY THE UTMOST ATTENTION TO TEXT BLOCKS INDICATED BY THIS SYMBOL.

**WARNING!**

May cause damage to the appliance and/or its components.

Be careful.

**WARNING!**

Warning or remark on key functions or useful information on the operation in progress.

## 1.2 PURPOSE OF THE MANUAL

This user manual is an integral part of the appliance and must be kept in its entirety and within the user's reach for the whole working life of the appliance.

The manual contains information on safety, technical aspects, operation, maintenance and spare parts. Its purpose is to provide the customer with the necessary information to use and control the appliance correctly, independently and safely.

**CAUTION**

Read this manual carefully and observe the instructions provided before using, testing and operating the appliance.

EN

### 1.3 CONSERVATION

The manual must be kept with care and near the appliance, protected from liquids and other substances that could compromise its readability and it **must be readily accessible at any moment**.

The manual and the Declaration of conformity are integral parts of the appliance, and therefore, they must accompany it during its whole working life.

### 1.4 UPDATING THE MANUAL

The information, descriptions, and illustrations contained in this manual reflect the state of the art at the moment of machine sale.

The Manufacturer, committed to the constant improvement of their products and/or for market reasons, reserves the right to make technical or commercial modifications to the appliances at any given moment without prior notice.

Any additions must be retained together with the manual and are to be considered integral parts of the manual.

### 1.5 CONFIDENTIALITY

The technical information (text, drawings and illustrations) provided in this manual is property of **DUPLEX INTERNATIONAL S.r.l.** and must be considered confidential.

It is strictly forbidden to disclose, reproduce or translate this document, even partially this document, unless authorised in writing by **DUPLEX INTERNATIONAL S.r.l.**

### 1.6 RECIPIENTS

This manual is addressed to personnel assigned to use the appliance for cleaning floors and carpets.

---

#### HAZARD!



**The appliance must not be used by children or by persons of reduced physical, mental or sensory capacity, or lacking in experience and knowledge in the use of the appliance, unless they are supervised and instructed on the safe use of the appliance by a person who is responsible for their safety.**

**Children should be supervised to ensure that they do not play with the appliance.**

---

## 2. GENERAL INFORMATION

### 2.1 MANUFACTURER IDENTIFICATION DATA

#### DUPLEX INTERNATIONAL Srl



Via Gobetti, 19-21-23  
50058 SIGNA - FLORENCE  
ITALY



Phone: +39 055 876437  
**UK 01227 771276**



Fax: +39 055 875229  
**UK 01227 770220**



Website: [www.duplexitaly.com](http://www.duplexitaly.com)  
**UK [www.duplex-cleaning.com](http://www.duplex-cleaning.com)**



e-mail: [infoduplex@duplexitaly.com](mailto:infoduplex@duplexitaly.com)  
**UK [info@duplex-cleaning.com](mailto:info@duplex-cleaning.com)**

### 2.2 LIABILITY LIMITATIONS

The manufacturer declines all liability for damage to persons or property caused by:

- Improper use of the appliance.
- Total or partial failure to comply with the given instructions.
- The appliance not being used in compliance with current regulations.
- Use not complying with national laws on safety and accident prevention.
- Tampering, with even a single part of the appliance.
- Incorrect installation and/or connection to the foreseen power sources.
- Use of non-original spare parts.

## 2.3 IDENTIFICATION PLATE

A plate **1** bearing the essential identification data required when requesting assistance or spare parts is applied to the appliance. The plate contains the following information:

EN

- A) Model
- B) Serial number
- C) Year of manufacture
- D) Weight

In addition to plate **1**, the Steam and Steam Plus models also have an identification plate **2** that indicates the code and serial number of the steam generator.



### CAUTION

Do not remove the identification plate for any reason.  
Please contact the Manufacturer in the event the identification plate gets damaged.

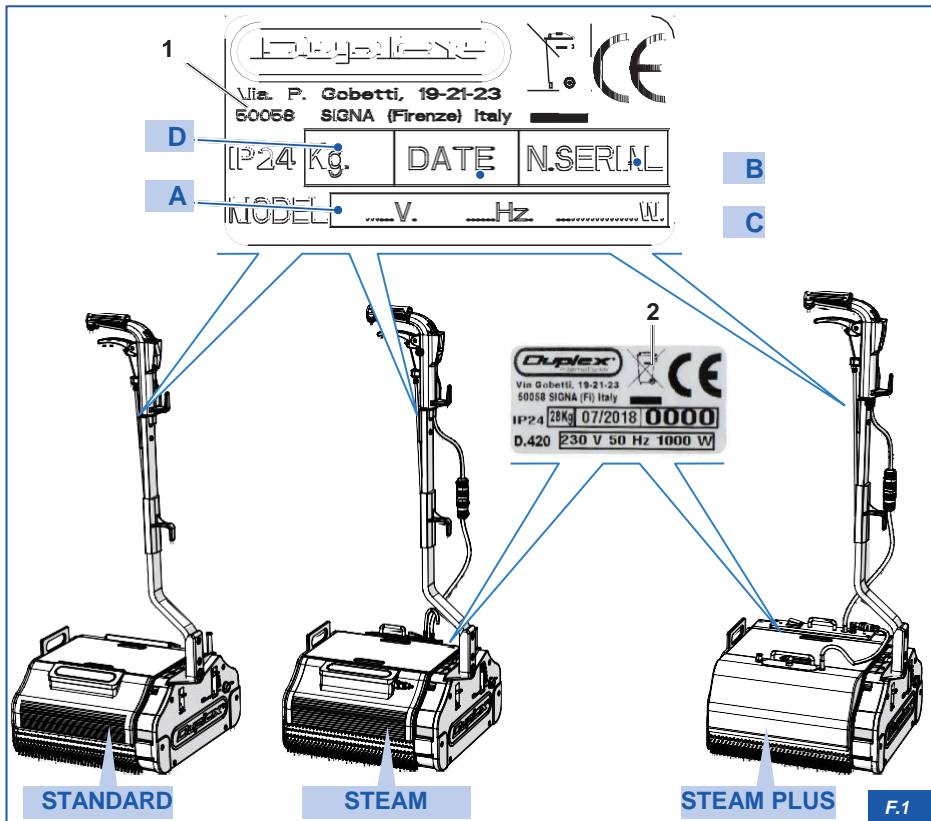

## 2.4 REFERENCE STANDARDS AND CONFORMITY

The appliance described in this manual complies with the following standards:

EN 55014-1:06 + A1:09 + A2:11,  
EN 55014-2:15,  
EN 60335-1:12 +A11:14,  
EN 60335-2-67:09,  
EN 61000-3-2:14,  
EN 61000-3-3:13,  
EN 62233:08

In compliance with the following provisions and Directives:  
2014/30/EU (Electromagnetic compatibility)  
2006/42/EC(Machinery Directive).



## 2.5 WARRANTY

DUPLEX UK guarantees this product against any manufacturing or material defects for a period one year from the date of purchase.

During this period DUPLEX will grant a free repair or substitution of any defective product at its discretion.

The substituted products or the repaired parts will only be guaranteed for the remaining time of warranty or for the following six months, depending on which period lasts more.

According to limits and terms provided for by the current laws, this limited warranty is not valid in the following cases:

- Improper or particularly demanding use of the machine;
- Lack of or incorrect daily maintenance;
- Wear and tear of consumable parts;
- The use of non-original spare parts;
- Damage due to natural events such as earthquakes, floods, fires or accidents;
- Tampering with or modification of the machine;

Damages caused by the use of unsuitable or inappropriate and/or corrosive chemical products such as highly acidic products: static dissipative detergents, hydrochloric acid, trichloroethylene, methyl ethyl ketone, acetone, pure ammonia, bleach and/or

- pure sodium hypochlorite or similar products;

Damage caused by normal wear of scrapers and brushes or by exposure to unsuitable

- weather conditions;

The maintenance booklet has been tampered with.

Furthermore, the terms and conditions of this warranty do not reduce nor edit what is provided for by the current laws about product sales to the customer.

In case the product is deemed defective, please contact DUPLEX International Srl to [support@duplexitaly.com](mailto:support@duplexitaly.com) or [info@duplex-cleaning.com](mailto:info@duplex-cleaning.com) the authorised Duplex Dealers who will communicate you the procedure to ask for a repair.

Page intentionally left blank

### 3. GENERAL SAFETY INSTRUCTIONS

This chapter gives the necessary information on how to use the appliance fully complying with the safety regulations in force.



#### CAUTION

The manufacturer declines all responsibility for any damage to property and/or persons caused by the failure to comply with the instructions provided in the following Chapter.



#### WARNING

Being familiar with the main safety standards and regulations is an essential requirement for using the appliance accordingly. The operator should observe the safety regulations in force in the country in which the appliance is being used.



#### HAZARD!

Follow all safety instructions indicated in this chapter for a safe use of the appliance.

#### 3.1 RESIDUAL RISKS

Residual risks are the risks that remain despite all safety measures were taken, as well as potential non-evident risks.

To avoid hazards to persons or damage to the appliance caused by residual risks, carefully follow the instructions provided in this manual.

Wait for all moving parts to come to a complete stop and / or for the components that are subject to heating to cool down completely before carrying out any work on the appliance. Follow the indications and warnings shown on the signs applied to the appliance and / or to its components.

## 3.2 GENERAL REQUIREMENTS

### CAUTION

**Read this manual carefully and observe the instructions provided before using, testing and operating the appliance.**



To avoid hazards to persons or damage to the appliance, follow the instructions and the code of conduct indicated below:

- The appliance was designed and constructed exclusively to clean floors. Any other use is considered improper.
- The appliance can be exclusively used by authorised and trained personnel.
- The appliance must not be used by children or by persons of reduced physical, mental or sensory capacity, or lacking in experience and knowledge in the use of the appliance, unless they are supervised and instructed on the safe use of the appliance by a person who is responsible for their safety.
- Children should be supervised to ensure that they do not play with the appliance.
- Remove the plug from the power socket before carrying out any cleaning or maintenance.
- Do not use the appliance if you notice any irregularities in its operation.
- In the event of a fault, have the appliance repaired exclusively by qualified technicians.
- Use only original spare parts.
- Do not pour water or liquids directly onto the appliance.
- Do not use acid-based detergents that could damage the appliance.
- Do not mix together detergents of different types to avoid the emission of harmful gases.
- Do not use the appliance to collect hazardous dusts.
- Be careful not to hit shelves or scaffolds when using the appliance to avoid objects falling down.
- DO not use the appliance in areas in which there are hazardous substances, particularly in potentially explosive atmospheres and/or under unsuitable micro-climatic conditions.
- Do not clean surfaces contaminated by flammable liquids.
- Switch off the appliance immediately after its use.
- Ensure the appliance does not rest on the brushes when it is in its rest position, but that it is supported and raised from the floor by the four retractable wheels. Otherwise, the weight of the appliance could deform the brushes.
- Store the appliance indoors in a dry place after use.
- Do not modify or tamper with the appliance.
- Do not remove the guards.
- Use only brushes supplied with the appliance or those specified in the instruction manual.
- Use personal protective equipment (PPE) suitable for the work to perform.
- Use a powder extinguisher in case of fire. Do not use water.

For the Steam / Steam Plus models:



**CAUTION**

In addition to the instructions already listed, the following precautions must also be followed for the Steam and Steam Plus models.

- Never leave the steam generator turned on or in operation if there is no water in the tank.
- After each use, turn off the illuminated switch on the handle and the main illuminated switch on the steam generator.
- Clean the outside of the steam generator with a damp cloth.
- Do not immerse the generator in order to prevent the infiltration of liquids.
- Regularly clean the spray nozzles with water using a brush and then dry.
- Keep the water tank clean.
- Replace the descaling filter at least once a year.
- When in use, the appliance reaches high temperatures. Do not touch the steam nozzles and the metal sides.
- Fill the water tank for generating steam as required. It should never remain empty.

### 3.3 ELECTRICAL HAZARDS



**ELECTRICAL HAZARD!**

Do not perform any type of intervention on live equipment (maintenance, cleaning, etc.).  
Disconnect the electrical power supply before working on the appliance.

#### 3.3.1 POWER CORD

- Regularly check that the power cord is intact and does not show signs of wear, cracking or peeling.
- **If the power cord is damaged, replace it before using the appliance.**
- Use a cable of the same type used by the Manufacturer, certified according to European standards.
- **Cable replacement must be performed by qualified personnel.**
- Do not use the appliance if the power cord or plug are damaged or if the appliance fell to the ground or got damaged in any way.
- Do not immerse the appliance, its power cord or plug in water or any other liquid.
- **Avoid any contact of the power cord with the brushes.**



- If the power cord becomes caught under the brushes of the appliance: STOP the appliance immediately. Do not for any reason try to release the power cord while the appliance is in operation. If the power cord is damaged, replace it.
- Do not pull on the cable to unplug the plug from the power socket.

### 3.4 SAFETY SIGNS

The appliance is equipped with plates and pictograms that quickly and easily draw attention to things and situations that can cause specific hazards, and in particular:

- Prevent dangerous behaviours;
- Warn the exposed persons of a risk or hazard;
- Prescribe safe behaviours;



---

**HAZARD!**

**It is strictly prohibited to remove the safety signs or alter their characteristics.**

---

Check that the safety signs are always perfectly legible;  
Replace damaged signs with other of the same type and make sure to apply them in their original positions.

### 3.5 NOISE LEVEL

The appliance was designed and constructed in such a way to minimise the noise emitted during its normal operation.

The weighted sound pressure level generated by the various components of the appliance is <64 dB (A). It was measured at the operator's ear in the work position during a normal work cycle and following the criteria outlined by the regulations in force.

The sound pressure level may vary considerably according to the work environment.

EN



#### WARNING

**Use appropriate personal protective equipment if you suffer a constant discomfort due to the noise produced by the appliance.**

### 3.6 VIBRATION LEVEL

The appliance was designed and constructed in such a way to minimise the level of vibrations generated during its normal operation.

The weighted whole body vibration level generated by the various components of the appliance is 0.95 m/s<sup>2</sup>.

## 4. TECHNICAL CHARACTERISTICS

### 4.1 GENERAL DESCRIPTION

The **Duplex** appliance was designed and manufactured to clean floors and carpets. During its design and construction, all necessary measures were taken to produce a high-quality, reliable product, fully compliant with the regulations in force and with particular regard to accident prevention.

This compact appliance is perfect for average size rooms and is able to reach even the tightest spaces.

This is achieved by means of its two-way handle that allows you to change the cleaning direction by simply reversing the handle.

The support casing and the whole structure is made of die-cast aluminium. It ensures that all components are sealed and prevents water and dust from penetrating into the inside of the appliances.

The appliance is fitted with a safety handle for switching it on and off immediately.

#### 4.1.1 PROPER AND IMPROPER USE



##### HAZARD!

**It is strictly prohibited to use the appliance under different conditions than those described in this manual. Any other different use of the appliance is not authorised and is dangerous (improper use).**

The choice of materials used to make the appliance was made according to the specific use to which the appliance will be put. Improper use can result in injury to persons and / or damage to property and affect the operation of the appliance.

The observance of the use, repair and maintenance instructions described in this manual, is an essential requirement to use the appliance correctly.

The use of the appliance for activities not foreseen during its design and which are not listed in this manual, shall relieve the Manufacturer of any direct or indirect liability.

Any arbitrary alteration made to the appliance shall relieve the Manufacturer of any liability for damage or personal injuries, even serious, caused to operators, third parties and/or property.

The correct use of the appliance, the careful observance of the instructions indicated in this manual and the strict application of all requirements to avoid hazardous situations, accidents or injuries, will contribute to making the appliance work better and longer, minimising faults and failures.



##### CAUTION

**The Manufacturer declines any responsibility for any damage to property and/or persons deriving from failure to observe the warnings indicated in this manual.**

## 4.2 DESCRIPTION OF THE COMPONENTS

EN

1	Motor Protector	11	Mop Up / Down
2	Handle	12	Transport wheels
3	Detergent/water release lever	13	Steam generator
4	Handle	14	Pump switch
5	Power cord	15	Motor
6	ABS detergent tank	16	Steam generator switch
7	Brush pressure regulator	17	Main switch
8	Cover	18	Safety handle (Start & Stop)
9	Recovery tank	19	ABS water tank with filter
10	Brushes	20	STAINLESS STEEL water tank with filter

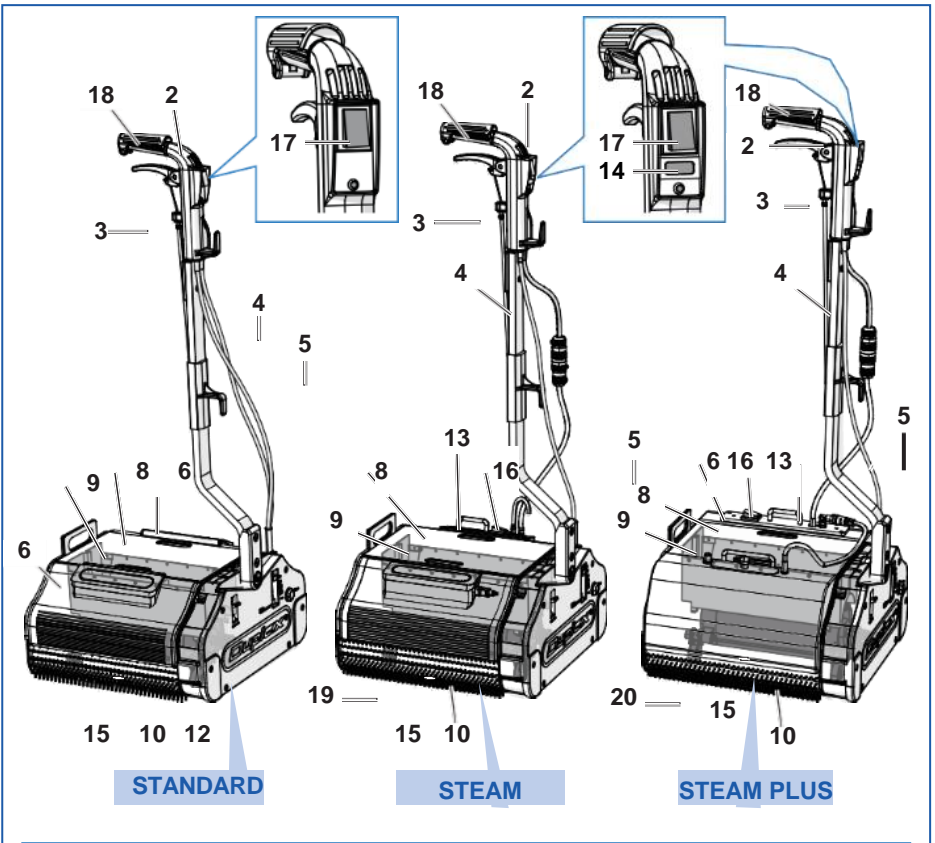

**STANDARD**

**STEAM**

**STEAM PLUS**

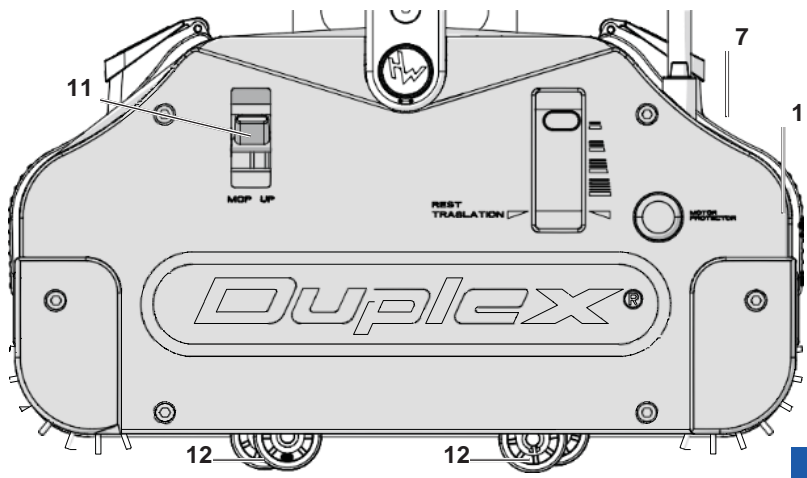

**F.3**

## 4.2.1 TECHNICAL SPECIFICATIONS

EN

		STANDARD								
		340			420			620		
Width	mm	340			420			620		
Length	mm				430					
Height	mm				240					
Brush diameter	mm				102					
Brush width	mm	280			350			550		
Tank capacity	l	4.2			5.4			9.5		
Recovery tank capacity	l	1.9			2.3			3.6		
Brushes pressure on flooring	g/cm <sup>2</sup>	190			190			160		
Theoretical working surface	m <sup>2</sup> /h	180			350			550		
Degree of protection	class				IP24					
Noise level and vibration	dBA				< 64					
rms value of the weighted vibration acceleration	m/s <sup>2</sup>				1					
Brush round-minute	rev./'1				650-750					
Electrical isolation	Class				I°					
Dry weight	Kg	27.5			27.5			37.5		
Vibration value	m/s <sup>2</sup>				0.95					
		MOTOR								
Voltage	Volt	220	240	117	220	240	117	220	240	117
Frequency	Hertz	50/60	50	60	50/60	50	60	50/60	50	60
Motor power	Watt	1000			1000			1600		

		STEAM								
		340			420					
Width	mm	340			420					
Length	mm				430					
Height	mm				250					
Brush diameter	mm				102					
Brush width	mm	280			350					
Tank capacity	l	2.1			2.7					
Recovery tank capacity	l	1.9			2.3					
Brushes pressure on flooring	g/cm <sup>2</sup>	190			195					
Theoretical working surface	m <sup>2</sup> /h	180			350					
Degree of protection	class				IP24					
Noise level and vibration	dBA				< 64					
Steam generator power	Watt	900		-		900		-		
Pump Power	Watt	16		-		16		-		
Steam jet width	mm	250			330					

		<b>STEAM</b>					
		<b>340</b>			<b>420</b>		
Steam jet duration	min.	60			60		
rms value of the weighted vibration acceleration	m/s <sup>2</sup>	1					
Brush round-minute	rev./'1	650	-	650	750	-	
Electrical isolation	Class						
Dry weight	Kg	30					
Vibration value	m/s <sup>2</sup>	0.95					
<b>MOTOR</b>							
Voltage	Volt	220	240	-	220	240	-
Frequency	Hertz	50/60	50	-	50/60	50	-
Motor power	Watt	1000	-	1000	1000	-	

		<b>STEAM PLUS</b>					
		<b>420</b>			<b>620</b>		
Width	mm	420			620		
Length	mm	430					
Height	mm	250					
Brush diameter	mm	102					
Brush width	mm	350			550		
Tank capacity	l	2.7			4.75		
Recovery tank capacity	l	2.3			3.6		
Brushes pressure on flooring	g/cm <sup>2</sup>	200			195		
Theoretical working surface	m <sup>2</sup> /h	350			550		
Degree of protection	class	IP24					
Noise level and vibration	dba	< 64					
Pump Power	Watt	16			16		
Steam jet width	mm	330			530		
Steam jet duration	min.	60			60		
rms value of the weighted vibration acceleration	m/s <sup>2</sup>	1					
Brush round-minute	rev./'1	650	750	650	-		
Electrical isolation	Class						
Dry weight	Kg	31.6			43		
Vibration value	m/s <sup>2</sup>	0.95					
<b>MOTOR</b>							
Voltage	Volt	220	240	117	240	220	-
Frequency	Hertz	50/60	50	60	50	50	-
Motor power	Watt	1000			1600		
Steam generator power	Watt	1340	900	1340		-	

## 4.3 TYPE OF DETERGENTS

EN



### HAZARD!

**Do not use detergents with the Steam and Steam Plus models. The use of detergents will damage the equipment. The Manufacturer will not be held liable for damage caused by the appliance due to the use of unsuitable detergents or non-compliant products.**

The appliance can be used with detergents intended for this type of appliance. To use the detergents, follow the detergent manufacturer's instructions relating to the dilution.

DO not use unsuitable detergents or aggressive and strong acid-based chemicals such as:

- Caustic soda
- Acids
- Diluents
- Solvents



### HAZARD!

**Read the labels on the detergent bottle carefully. Detergents can have harmful impacts on the environment and the human body in case of inhalation, ingestion or contact with skin and mucous membrane. If necessary, use personal protective equipment (PPE) while using detergents.**



### CAUTION

**Static dissipative detergents can damage the brushes and plastic parts of the appliance. The manufacturer declines any liability for damage caused to the appliance or flooring of any kind, including carpets and rugs, due to the use of non-compliant detergents or products.**

## 5. ASSEMBLING THE APPLIANCE

For packing and transport purposes, the appliance is delivered disassembled. Check that the packing contents making sure that the appliance's components are all present and in good conditions.



### WARNING

Contact the Customer Service Centre 01227 771276 UK if some components are missing or damaged.



### CAUTION

Follow the instructions contained in this chapter carefully in order to assemble the appliance correctly.

## 5.1 PACKING CONTENTS

Check that the appliance's components inside the packing match those indicated in the table below:

EN

	PACKING CONTENTS	STANDARD	TEKNA (Dual Handle)	STEAM	STEAM PLUS
1	Appliance	✓	✓	✓	✓
2	Handle with lever	✓	-	✓	✓
3	Elbow for handle	✓	-	✓	✓
4	Certificate of Compliance	✓	✓	✓	✓
5	ABS detergent tanks	✓	✓	✓	✓
6	Steam generator tank (ABS)	-	-	✓	-
7	Steam generator tank (stainless steel)	-	-	-	✓
8	Water tank with filter (ABS)	-	-	✓	-
9	Water tank with filter (stainless steel)	-	-	-	✓
10	Recovery tank	✓	✓	✓	✓
11	All-purpose grey brushes	✓	✓	✓	✓
12	Stainless steel elbow	-	✓	-	-
13	Screws, keys	✓	✓	✓	✓
14	Double handle	-	✓	-	-
15	Cord hook	✓	✓	✓	✓
16	Use and maintenance manual	✓	✓	✓	✓
17	Plate	✓	✓	✓	✓
18	Elbow for double handle	-	✓	-	-
19	Double handle insert	-	✓	-	-

**STANDARD**

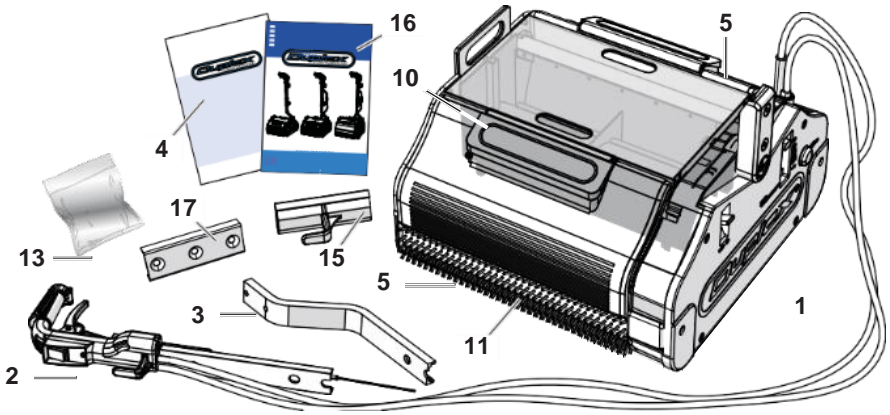

**TEKNA (Dual Handle)**

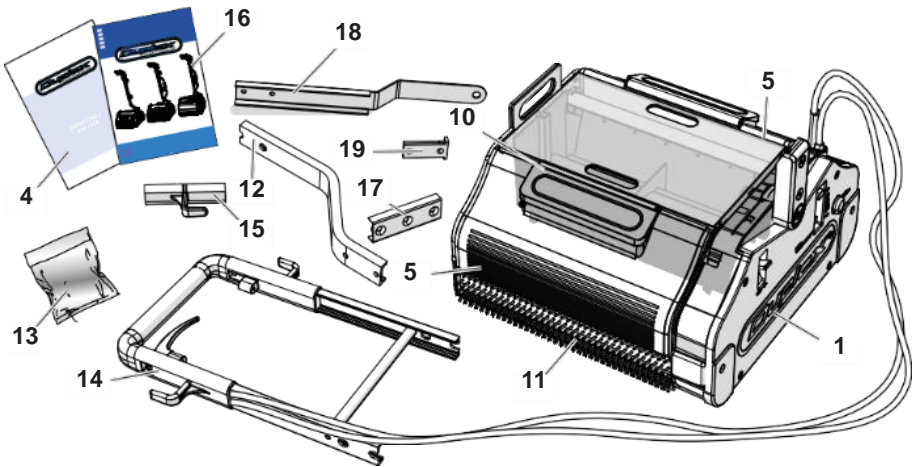

STEAM

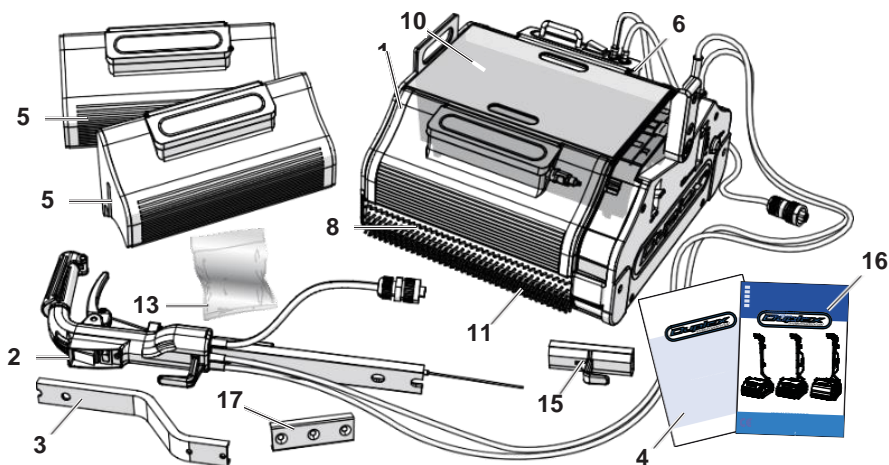

STEAM PLUS

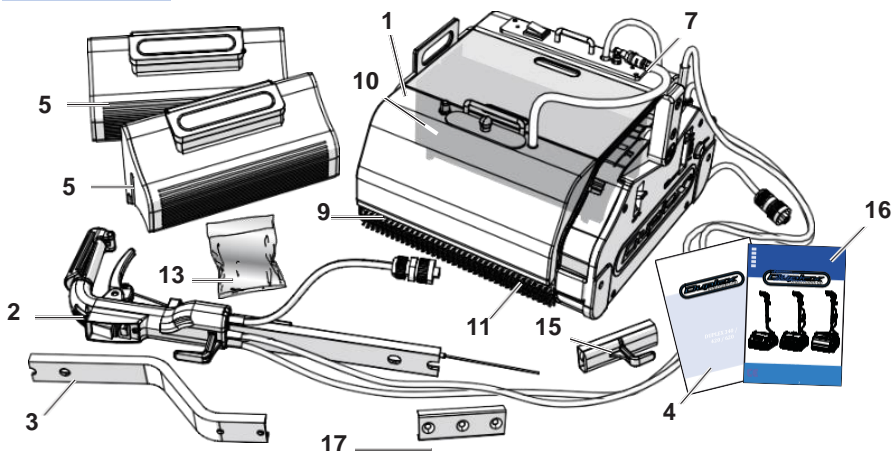

F.5

## 5.2 ASSEMBLING THE HANDLE



### WARNING

Use the supplied hex wrench to assemble the handle as follows:

To assemble the handle, proceed as follows:

- 1) Insert the elbow of the handle **1** into the seat of the articulated support **2**.
- 2) Tighten the two screws **3** using the 5mm allen key provided and tighten well.
- 3) Assemble the handgrip of the handle **4** by pushing it through the connecting plate **5** making sure that the screws **6** face inwards and that the cable-hook **7** faces downwards.
- 4) Tighten the three screws **6** using the same allen key provided.

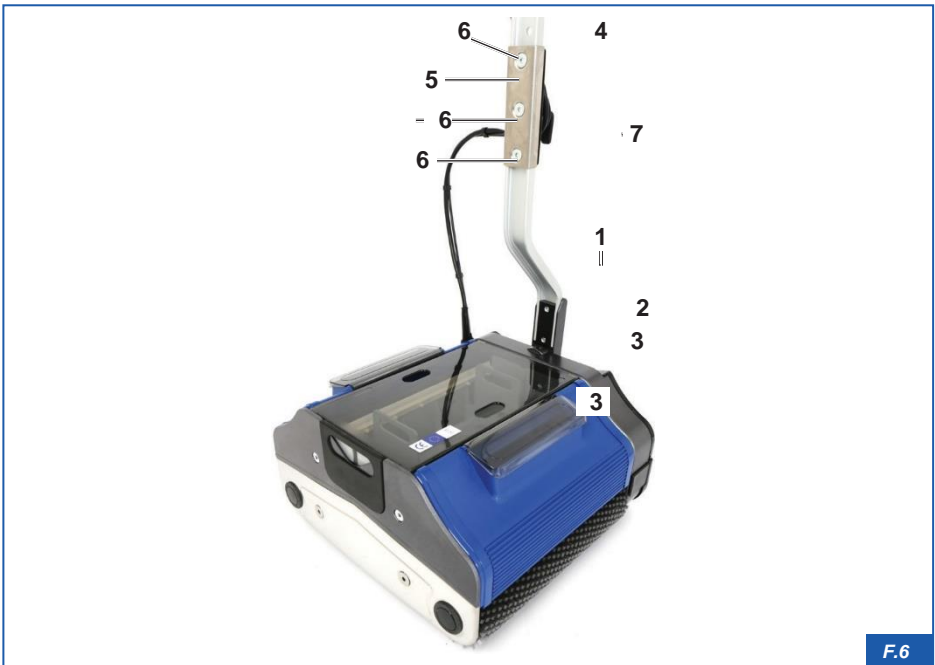

F.6

EN

- 5) Adjust the screw **8** of the tensioning regulator **9** located under the lever **10** of the handgrip paying attention to the movement of the feelers **11** that allow the liquid to flow from the tanks.
- 6) Make sure that the feelers **11** remain flush with the side panel when the lever **10** is not pulled



**CAUTION**

If the feelers protrude it may not be possible to insert or extract the tank containing the liquid from their housings. Use a screwdriver on the feelers to adjust their position either inwards or outwards.

**For the Steam / Steam Plus models**

- 7) Join the two connectors **12** on the cable **13**

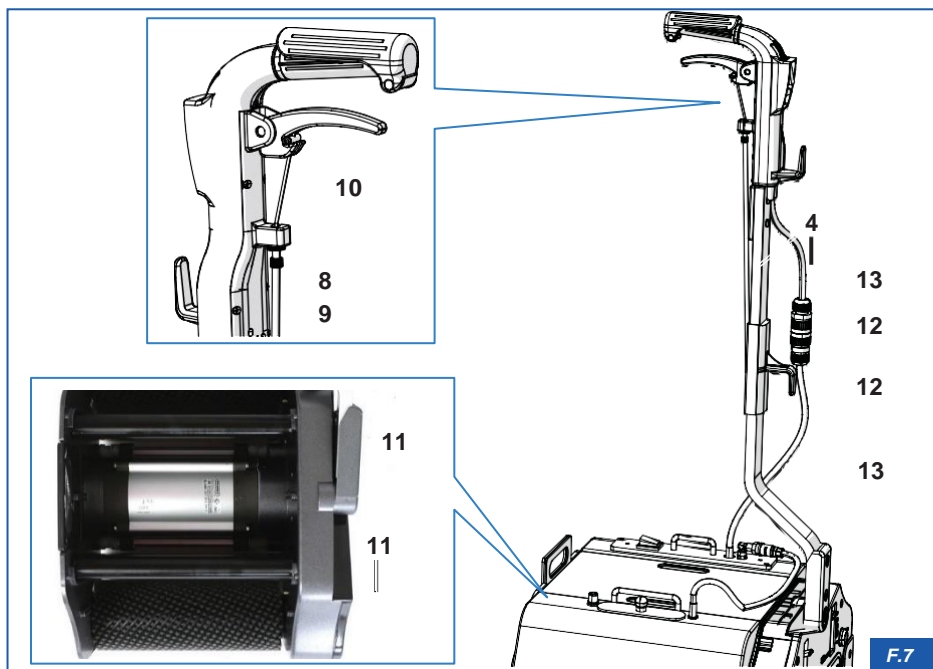

### 5.2.1 ASSEMBLING THE HANDLE - TEKNA MODEL (DUAL HANDLE)

- 1) Introduce the elbow **1** into the seat of the support **2**
- 2) Tighten the two screws **3** using the allen key provided and tighten well
- 3) Install the second elbow **7** using the fixing screws **8** and **9**.
- 4) Install the pre-assembled handle **4** using the joining insert **10** and the screws **11**
- 5) Join the opposite side of the pre-assembled handle **4** using the connecting plate **5** and the cable-hook joint **16** using the three screws **6** facing inwards and tighten using the same screwdriver.
- 6) Adjust the screw **12** of the tensioning regulator **13** located under the lever **14** of the handgrip
- 7) paying attention to the movement of the feelers **15** that allow the liquid to flow from the tanks.
- 8) Make sure that the feelers **15** remain flush with the side panel when the lever **14** is not pulled.

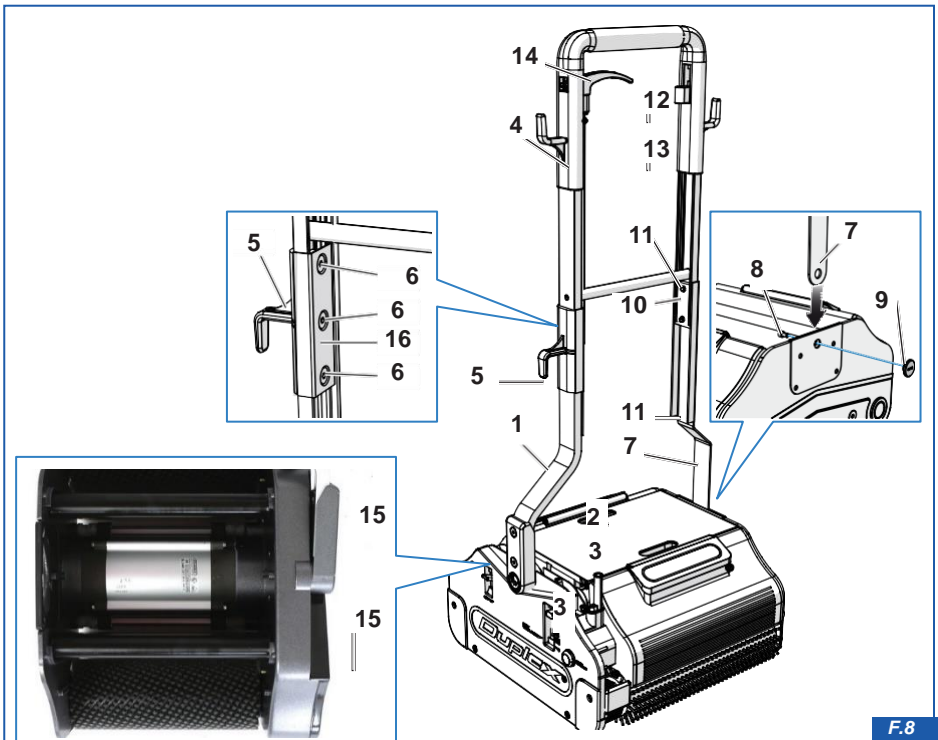

F.8

## 5.2.2 DISASSEMBLING THE HANDLE

---

EN

**HAZARD!**

Before removing the handle, make sure that the appliance has been disconnected from the mains supply.

---

To disassemble the handle, follow the assembly instructions in the reverse order.

## 6. OPERATION AND USE

### 6.1 FILLING THE APPLIANCE WITH THE WASHING LIQUID

In the Duplex STANDARD model, the washing solution is contained in two tanks that must be filled to the same level in order to keep the appliance balanced.

In the Duplex STEAM and STEAM PLUS models, the water used for cleaning is contained in one tank, while the other houses the steam generator to produce the steam.

Additionally, the STEAM PLUS model is equipped with a level indicator (1) that makes it easier to check the amount of water remaining in the tank.

All tanks can be easily removed and filled directly under a tap or by pouring in the detergent or water from a container.



#### CAUTION

The manufacturer declines any liability for damage caused to the appliance or flooring of any kind, including carpets and rugs, due to the use of non-compliant detergents or products.



F.9

EN

## 6.2 STARTING THE APPLIANCE

- 1) Make sure that the handle is in the rest position (perfectly vertical) and that the regulator is in the “Transport” position (REST TRASLATION).
- 2) Plug the cable into an earthed socket.
- 3) Place the regulator to one of the four available positions according to the type of cleaning to be carried out.

(MU= Mop-Up : Insertion of dirt collector)

1	Heavy duty wash for very dirty floors.
2	Delicate wash for all types of floors.
3	Normal carpets and wooden floors.
4	Long-pile carpets.
5	Transport position / disable appliance (REST TRASLATION)



### CAUTION

To clean the carpet, it is recommended to use the yellow brushes, which have been specifically designed to clean rugs and carpets.

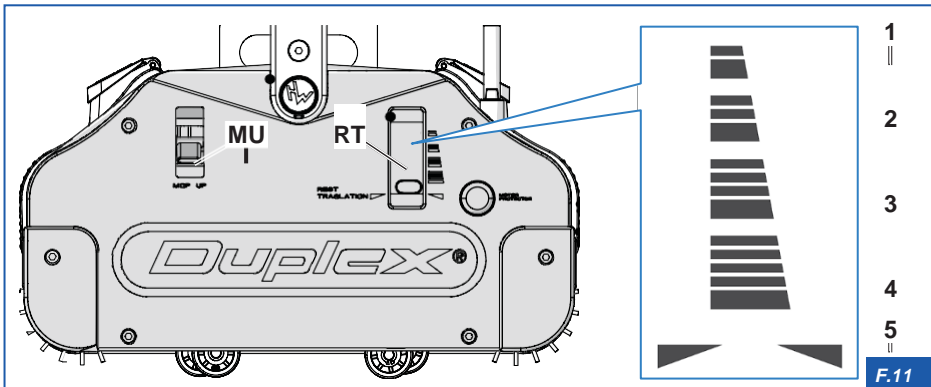

### 6.3 OPERATING PROCEDURE FOR ALL MODELS

- 1) Press the main switch on the handle.
- 2) Grip the handle and press the safety lever. Slowly lower the handle on one of the sides. The appliance will start up and the revolving brushes will start working on the floor.
- 3) Move the appliance slowly forwards, going over the same washing path with the recovery device MU (MOP UP) enabled.
- 4) When the appliance is moving forwards, dispense the washing solution by activating the lever underneath the handle at short intervals, taking care not to flood the floor.

When in use, the dirty water is collected immediately in the recovery tank 1 that must be emptied as soon as it is full by removing it from its seat.

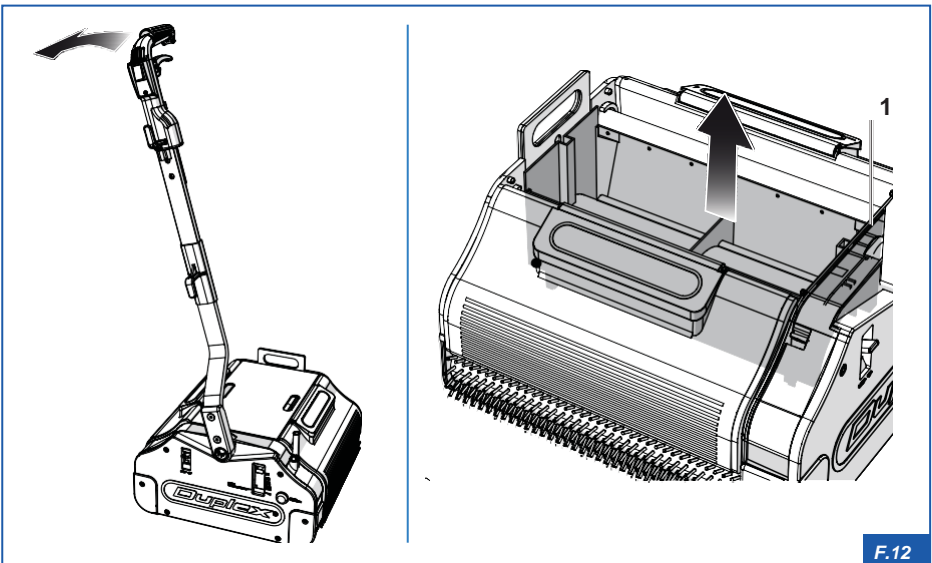

F.12

## 6.4 HOW TO WASH FLOORS

EN

### 6.4.1 STAGE 1

- 1) From the starting position, move forward towards the corner as indicated in the figure.
- 2) Once you have reached the corner, move backwards with the appliance and keep cleaning the strip until you reach your starting position.
- 3) From the starting position move to the second lane to wash slightly overlapping the area you have cleaned before.
- 4) Repeat this operation until you complete stage 1.
- 5) Clean the outer edge on the opposite side of the cleaning area, reversing the appliance.

### 6.4.2 STAGE 2

- 1) Reverse the cleaning direction of the appliance by using the handle.
- 2) Repeat the operations described in Stage 1.

The possibility of reversing the position of the handle allows the operator to easily work in both directions and to clean and wash floors and carpets thoroughly.

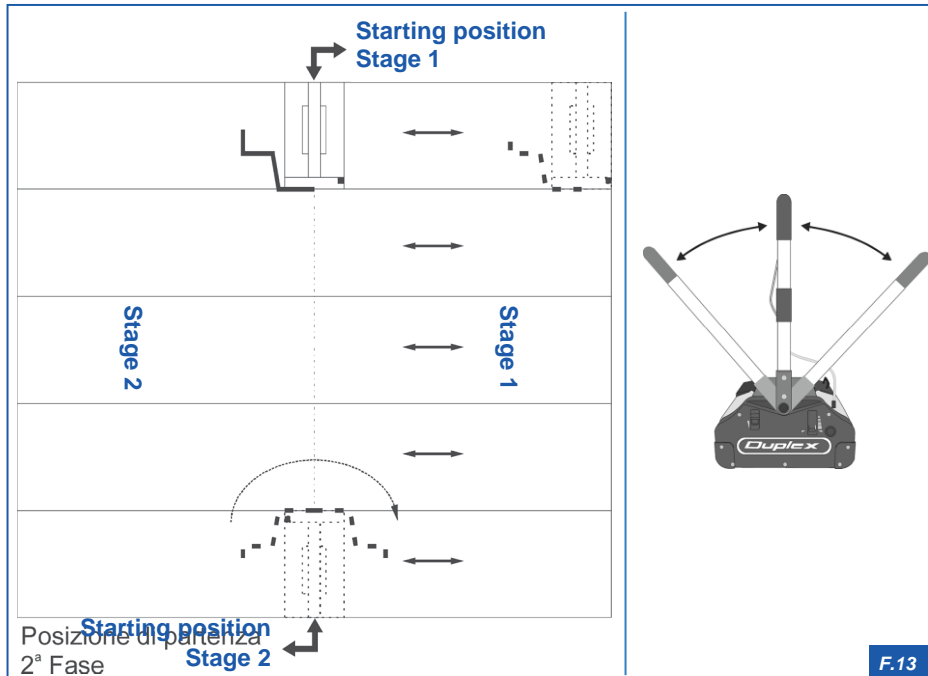

F.13

## 6.5 FOREWORD: STEAM AND STEAM PLUS



### ECOFRIENDLY STEAM MACHINES

**By taking advantage of the steam energy and the brushes pressure for the floorings and carpets cleaning WITHOUT THE USE OF DETERGENTS.**

Washes, restores, dries and sterilises all types of flooring by means of powerful steam jets. The steam jet is directed on the floor at a high temperature facilitating the removal of even the most stubborn dirt.

The steam sprayed close to the floor is even more effective in the removal of greasy and stubborn dirt on either hard, smooth or profiled flooring.

This steam jet washing system is particularly effective on textile flooring such as CARPETS and RUGS etc, as it not only washes the textile fibres but it re-vitalizes them as well.

The appliance is equipped with two standard tanks that can also be used conventionally with water and detergent.

On the STEAM and STEAM PLUS models, two tanks are used, one contains and supplies the water and the other contains the steam generator.

### 6.5.1 STEAM GENERATOR OPERATION

The steam generator that produces the steam (DUPLEX STEAM model) is equipped with self-testing devices capable of blocking operation at any time and under any work circumstance to prevent accidents that could damage people or objects. The steam production system works in continuous mode without a pressurised boiler.

A special resin filter located inside the tank softens the water in order to reduce any calcification.

To generate steam pour only water into the tank. (and 50ml Hydroscale (in the UK))

### 6.5.2 USING THE STEAM AND STEAM PLUS MODELS

- 1) Press the following switches in sequence:
  - A) Main power switch 1
  - B) Steam generator switch 2
  - C) Pump switch, after a few minutes 3
 The appliance will begin to emit steam continuously.
- 2) Slowly lower the handle whilst pressing the safety lever 4 at the same time. Move the appliance forwards along the same cleaning strip.
- 3) When the appliance is moving forwards, actuate the water dispensing lever located below the handle 5 at short intervals, whenever it is necessary to wet the floor a bit more, taking care not to flood it.

During use dirty water will be collected instantly inside the

recovery tank which must be emptied as soon as it is full, by removing it from its seat.

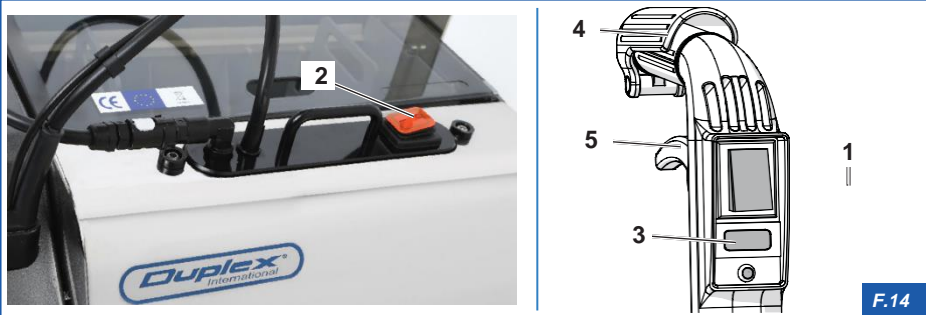

#### CAUTION



- The water tank for delivering the steam should never be empty. STEAM PLUS model is equipped with a level gauge for water.
- The disposal of the dirty water must be carried out in compliance with the regulations in force.

#### WARNING



**Models STEAM and STEAM PLUS: do not place detergents in the water tank. The use of detergents will irretrievably damage the equipment.**

**The Manufacturer will not be held liable for damage caused by the appliance due to the use of unsuitable detergents or non-compliant products.**

### 6.5.3 USING ABS DETERGENT TANKS ON STEAM AND STEAM PLUS MODELS

The Steam and Steam Plus models are equipped with a pair of ABS detergent tanks **6** for cleaning floors with water and a detergent solution.



**HAZARD!**

Before proceeding, make sure that the appliance has been disconnected from the mains electricity supply.

In order to install the tanks **6**:

- 1) Disconnect the water supply hose **7**.
- 2) Disconnect the two connectors **8** on cable **9**.
- 3) Remove the water tank with filter **10** and the steam generator tank **11**.
- 4) Install the ABS detergent tanks **6**.
- 5) Use the appliance in standard mode.

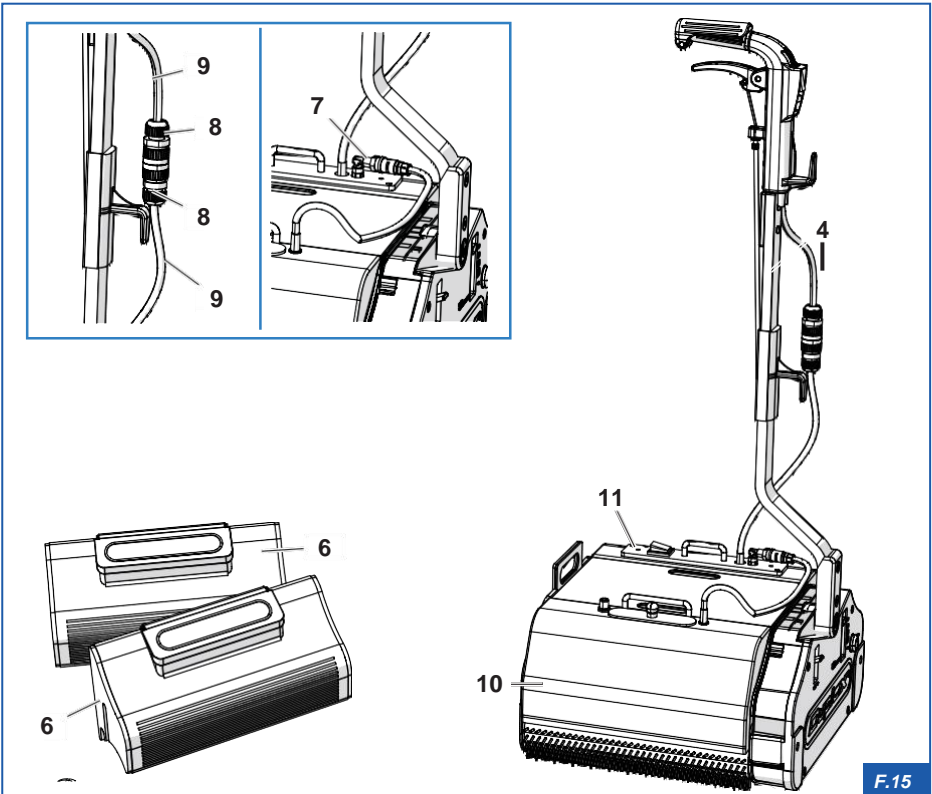

F.15

## 6.6 FLOOR CLEANING TIPS

The original DUPLEX brushes are tested and balanced individually with special electronic instruments and guarantee the absence of vibrations that could generate mechanical stress for the appliance and the floors.

The brushes can have different colours according to their use characteristics:

BRUSH COLOUR	USE
Light grey	All-purpose for light dirt of all types of flooring (standard supply).
Black (soft)	All-purpose for heavy dirt and less delicate floors.
Black (hard)	For scraping off resistant dirt. For this kind of use, it is sufficient to fit the appliance with one "hard" brush combined with a black "medium hard" brush.
Yellow	For cleaning carpets, rugs, wooden floors and particularly delicate floor surfaces.
Yellow	Polishing brushes for polishing smooth surfaces.
Dark grey (Tynex)	Very abrasive brushes used for removing paint, lime, cement deposits and other products, even when dried hard on industrial and resistant floors: stoneware, porphyry, clinker, terracotta etc. (These brushes can be used normally with water and detergents). For this kind of use, we recommend using one Tynex brush combined with a softer, grey, all-purpose brush or black medium hard brush.
	<b>CAUTION: due to their abrasive power they may cause damage to floors.</b>

### 6.6.1 CLEANING EXTREMELY DIRTY FLOORS

Reaction phase:

Let the detergent to act on the floor and allow the brushes and / or steam to remove the dirt. To disable the detergent recovery device, proceed as follows:

- 1) Stop the appliance (if in operation).
- 2) Put the MOP-UP lever in the up position.

Then, by positioning the MOP-UP lever downwards the automatic dirty water recovery system will be re-activated.

**CAUTION**

The MOP-UP lever must only be moved when the appliance is stopped. Thoroughly clean the appliance and brushes after cleaning extremely dirty floors and before cleaning delicate floors.

**WARNING**

This procedure is not recommended for carpets, rugs and wooden floors.

### 6.6.2 CLEANING CARPETS AND RUGS

Using the slider control, select the correct position (normal carpets / long pile carpets). We advise you to cross the washed tracks so that all fibres appear well cleaned taking care not to wet them too much. (Make several trial runs before proceeding with the full washing operation).

### 6.6.3 CLEANING WOODEN FLOORS

Do not wet the floor excessively, especially non varnished floors that absorb water more readily. In any case, be very careful with these types of floor and preferably carry out a few tests before washing all of it.

### 6.6.4 USING WAX CLEANERS

Wax treatments allows the entire surface to be thoroughly washed, obtaining an optimal "polished look" and an instantaneous recovery of the dirt in a simple, fast and cheap manner.

It is extremely suitable for the following floor types:

- Terracotta
- Smooth tiles
- Clinker
- Marble
- Granite
- Studded rubber flooring

**Proceed as follows:**

- 1) Use the appliance with the two grey brushes provided.
- 2) Fill the two tanks with the appropriate detergent (can be requested to the Manufacturer) mixing it with water according to the instructions contained on the bottles;
- 3) Proceed with the usual washing system.

After washing, we recommend going over the surface using the brown polishing brushes to give a greater shine to the floor.

**EN**

### **6.6.5 POLISHING FLOORS USING LIQUID WAX**

After having spread a thin layer of liquid wax evenly on the floor, wait until the wax has completely dried.

Then vigorously brush the floor using the brown dry polishing brushes.

## 6.7 STOPPING THE APPLIANCE

To stop the appliance:

### Standard Model:

- 1) Move the handle to the vertical position and release the safety lever 4
- 2) Turn off the main switch located on the handle 1.
- 3) Move the regulator to the RT position (rest traslation).

### Steam and Steam Plus Models:

In addition to the instructions above:

- 4) Turn off the switches for the pump 3 and steam generator (located on the tank) 2



### CAUTION

Turn off the main switch (1) whenever the appliance is not in use.

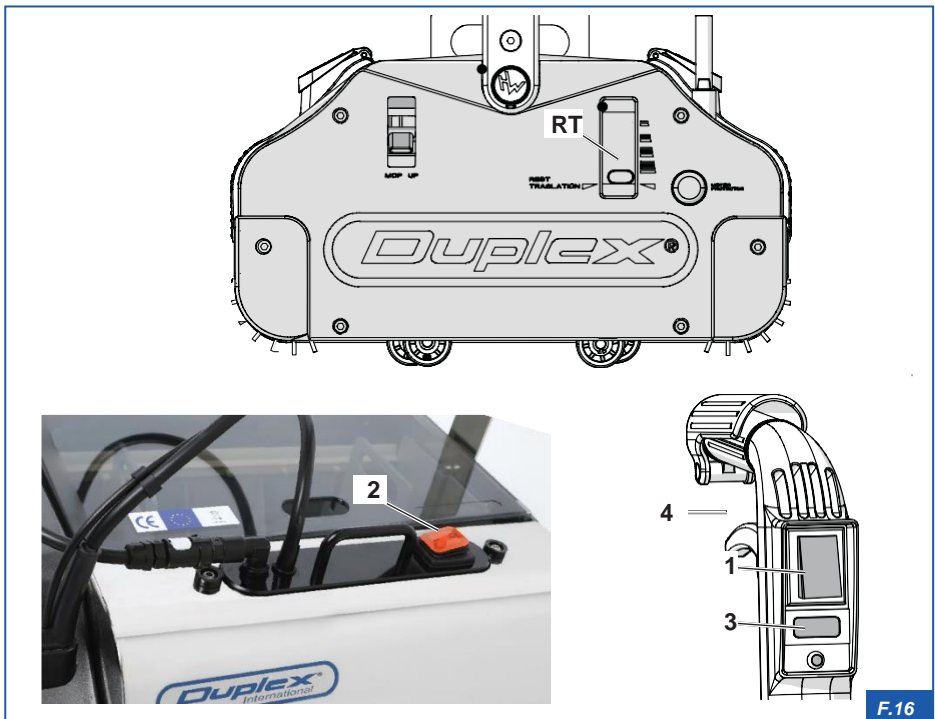

F.16

## 6.8 TRANSPORT

The appliance is transported using the four retractable wheels that allow for easy movement.

EN

To transport the appliance proceed as follows:

- 1) Move the handle to the vertical position (rest position);
- 2) Move the regulator to the **RT** position (REST TRASLATION);
- 3) Lower the handle from either of the two sides and push the appliance in the required direction.

### 6.8.1 TRANSPORT TROLLEY

The trolley is an optional accessory that makes it easier to transport the DUPLEX appliance, also over floors that have an irregular surface or up and down stairs.



F.17

## 6.9 AUTOMATIC MOTOR PROTECTION "MOTOR PROTECTOR"

The "Motor Protector" is a safety device that stops the appliance in case conditions arise that overload the electric motor (e.g. foreign bodies caught in the brushes that can prevent them from rotating, poor power supply, overheating, etc.).

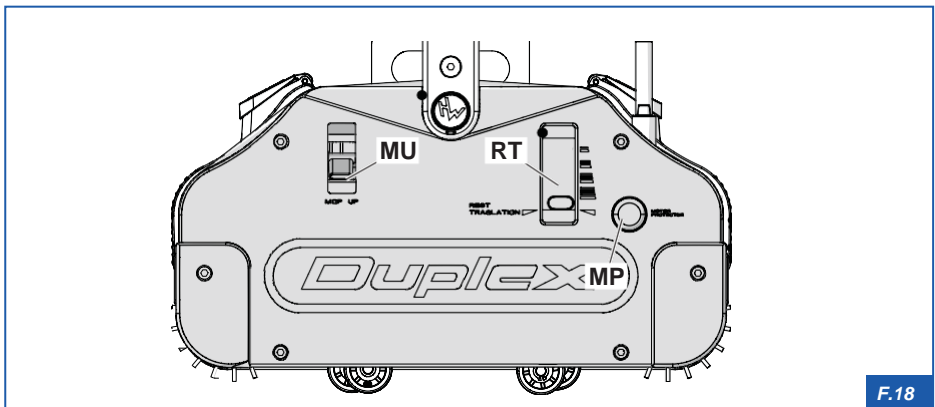

### ELECTRICAL HAZARD!

**Disconnect the appliance from the power socket before removing any foreign bodies that may be caught in the brushes.**

After having tried to find and eliminate the cause of the motor overload, press the "Motor protector" button (after about 60 seconds) to restart the appliance.

## 7. MAINTENANCE

We recommend carrying out routine maintenance interventions to keep the appliance in good working order.

EN



### ELECTRICAL HAZARD!

The appliance must be disconnected from the mains power supply before carrying out maintenance, replacing parts or cleaning the appliance.

### 7.1 CLEANING



#### CAUTION

- Do not use steam jets to clean the appliance.
- Do not use pressurised water jets.
- Do not use corrosive substances.
- Do not use rough, abrasive materials or sharp metal scrapers.



#### WARNING

Cleaning operations require just a few minutes and are essential to keep the appliance in good working order at all times.

To clean the appliance, proceed as follows:

- 1) Disconnect the power cord plug from the socket.
- 2) Remove the cover 1.
- 3) Remove the recovery tank 2.
- 4) Remove the tanks 3.
- 5) Wash the tanks and the recovery tank and dry them.

**CAUTION**

Apart from the tank that encloses the steam generator (Steam / Steam Plus models), the tanks can be washed under running water. Pay particular attention to dirt and / or foreign objects that could clog the valves (7) inside the tanks.

- 6) Remove the brushes 4 and clean them (see section “7.2.2 Cleaning the brushes”).
- 7) Clean the rest of the appliance thoroughly using a wet sponge and then dry it.
- 8) Remove any residues of dirt from all the appliance using a brush.
- 9) Once dry, replace all the components that were previously removed.



**F.19**

### 7.1.1 CLEANING THE DRIP CHANNELS

In order to clean the drip channels 6

- 1) Unscrew the screw 7
- 2) Remove the drip channels 6 from the tanks by gripping them at the centre and pulling them upwards and out from the two side seats (A). Clean the holes in the drip channels using a needle (B).

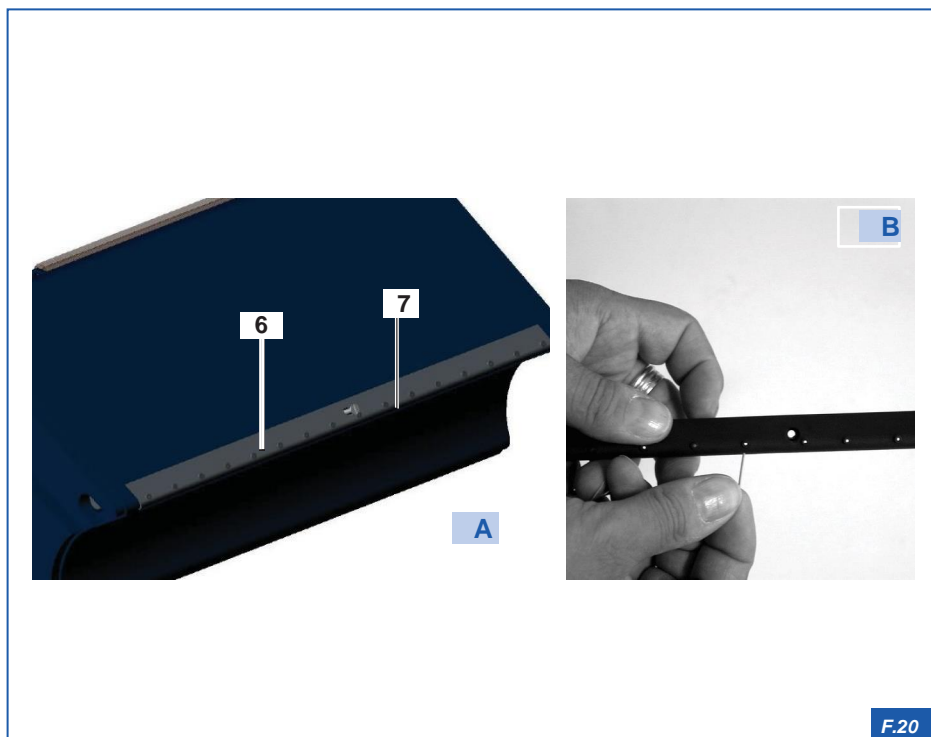
EN



F.20

## 7.2 BRUSH MAINTENANCE

Brushes require little routine maintenance. The high rotation speed during cleaning manages to centrifugate dirt and keep them clean and efficient at all times.

At the end of each use, check the status of the brushes **7** and clean or replace them, if necessary. (Soak overnight in mild detergent)



### **ELECTRICAL HAZARD!**

**The appliance must be disconnected from the mains power supply before carrying out maintenance, replacing parts or cleaning the appliance.**



### **HAZARD!**

**Do not use the appliance with worn or warped brushes. They can cause jerks or excessive vibration.  
Replace the brushes to avoid damaging the appliance.**

## 7.2.1 REPLACING THE BRUSHES

In case of wearing, warping or simply for replacement of the brushes with brushes more suitable for the type of cleaning required, proceed as follows:

EN

- 1) Unscrew the screws **8** using the key provided.
- 2) Remove the two brushes **5** together with the cover **9**.
- 3) Separate the brushes **5** from the cover **9**.
- 4) Fit new or optional brushes following the procedure in reverse.

## 7.2.2 CLEANING THE BRUSHES

Check the status of the brushes **7**, and if necessary, proceed as follows:

- 1) Remove the brushes **5** (see procedure in section "7.2.1 Replacing the brushes").
- 2) Immerse them in a container of lukewarm water and let them soak for a few hours.
- 3) Stir and rinse well.
- 4) Refit the brushes **5**, reversing their original position. This is necessary because the bristles tend to bend when the brushes **5** always rotate in the same direction.

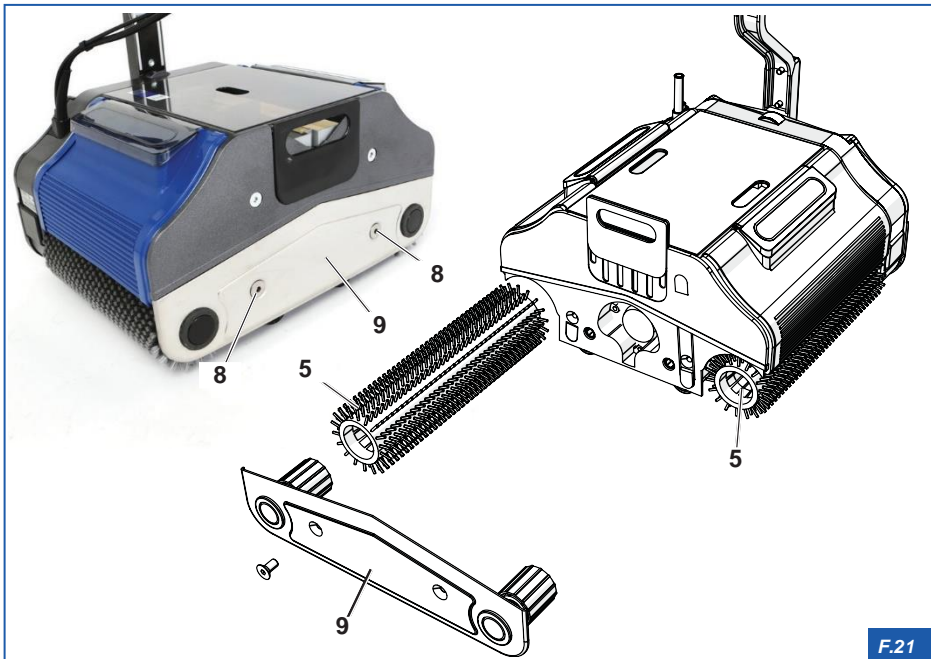

F.21

### 7.3 REPLACING THE SCRAPERS (TRIMMERS)

Keep the two recovery tank **5** scrapers **10** clean at all times.

Replace them approximately every 150 work hours or when they are visibly worn.

To replace the scrapers **10**, proceed as follows:

- 1) Remove the cover **1** (F.18).
- 2) Remove the recovery tank **5**.
- 3) Unscrew the screws **11** and remove the worn scrapers **10**.
- 4) Replace the scrapers **10** and tighten the screws **11**.

### 7.4 CONVEYORS

The conveyors **14** have an unlimited lifespan.



#### CAUTION

**Do not use the appliance to collect sharp object that could cut through the rubber.**

In order to always keep the belts **14** in good working order, we recommend cleaning them periodically and lubricating them with Duplex silicone spray. (SIL400)

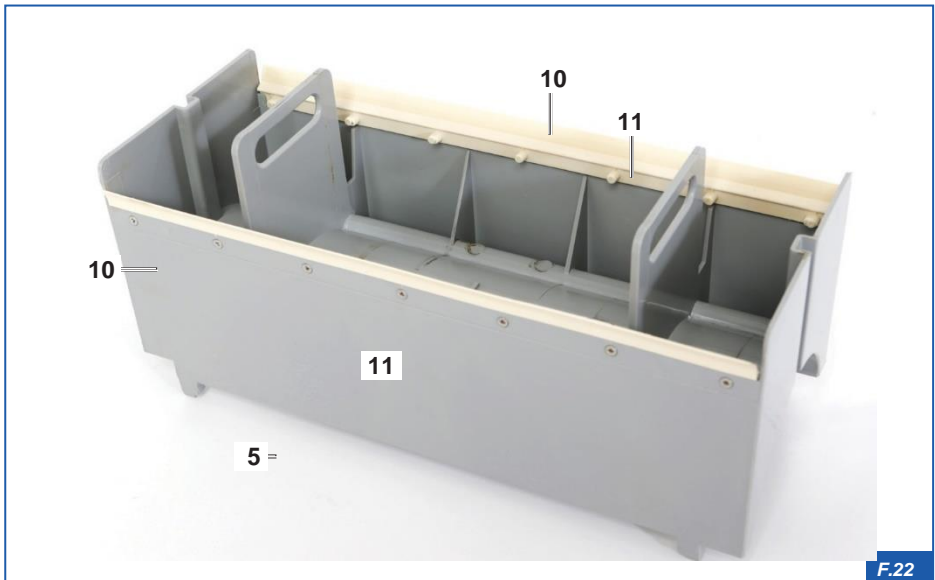

F.22

## 7.5 DESCALING (STEAM / STEAM PLUS MODELS)

We recommend descaling the system every time you notice a reduction in the steam jet. Use Hydroscale regularly as directed. For periodic descaling, use Hydroscale undiluted and follow the steps below.

EN

- 1) Place the appliance either on top of waterproof fabric or over a collection tank (the descaling product could damage the floors).
- 2) Fill the tank with undiluted Hydroscale
- 3) Turn on the switches to activate the steam function, without starting the brushes.
- 4) Wait until the solution has completely finished.
- 5) Turn off the steam function using the appropriate switches.
- 6) Rinse the tank and fill it with water.
- 7) Turn the steam function on using the appropriate switches.
- 8) Let the steam escape for about 10 minutes (the time necessary for washing and rinsing the nozzles).

At the end of this operation all the lime scale will be eliminated, together with all traces of the descaling product.

The perforated dispenser that squirts the steam towards the floor is made of special inert material (Teflon) that ensures its cleanliness as it prevents lime scale from adhering to the surface.

## 7.6 CLEANING AND REPLACING THE FILTER (STEAM /STEAM PLUS MODELS) REPLACE EVERY 12 MONTHS

A resin filter located inside the tank softens the water in order to reduce any lime scale.



### CAUTION

Is advisable to replace the filter at least once a year.

## 7.7 POWER CORD



### HAZARD!

Cable replacement must be performed by qualified personnel.



### ELECTRICAL HAZARD!

Do not use the appliance if the power cord or plug are damaged.

- Check the power cord regularly to see if there is any sign of damage: cracking, peeling, ageing.
- If the power cord is damaged, replace it before using the appliance.
- Use a cable of the same type used by the Manufacturer, certified according to European standards.
- If the power cord becomes caught under the brushes of the appliance: STOP the appliance immediately. Do not for any reason try to release the power cord while the appliance is in operation. If the power cord is damaged, replace it.

## 7.8 ROUTINE MAINTENANCE TABLE

EN

OPERATION	INTERVENTION	FREQUENCY
<b>Cleaning</b>	Tanks	After each use.
	Scrapers	After each use.
	Recovery tank	After each use.
	Appliance cleaning	After each use.
<b>Checks</b>	Brushes	Every 50/100 hours.
	Power cord.	Before and during each use.
<b>Replacement</b>	Mechanical and drive elements	24 months / around 500 work hours.
	Scrapers	Around 150 work hours.
	Standard grey brushes	Around 250 work hours.

## 7.9 DISPOSAL

This product falls within the scope of Directive 2012/19/EU regarding the management of waste electrical and electronic equipment (WEEE).

The appliance must not be disposed of together with domestic waste as it is made of different materials that can be recycled at appropriate facilities. Ask your local council where the recycling facilities are located that can take the product for disposal and its subsequent recycling.

It should also be remembered that when you purchase of an equivalent appliance, the distributor must collect the old product for disposal free of charge.

The product is not potentially hazardous for human health or the environment as it does not contain harmful substances as indicated in Directive 2011/65/EU (RoHS), but if improperly disposed of it can have a negative impact on the ecosystem.

Read the instructions carefully before using the appliance for the first time. It is recommended that you do not use the product for any purpose other than that for which it is intended, as there is a risk of an electric shock if it is used improperly.



**The crossed out wheeie bin symbol on the label attached to the appliance indicates that the product complies with the regulations regarding waste electrical and electronic equipment.**

**The equipment must be disposed of carefully; incorrect or illegal disposal is punishable by law.**

### 7.9.1 DIFFERENTIATION AND SORTING OF THE MATERIALS

#### **Electrical components:**

Material that can be disposed of with the urban waste collection, in compliance with the legal provisions in force in the country of use.

#### **Mechanical components:**

The appliance is made of aluminium, steel and plastic materials.

Steel and aluminium will not damage the environment if recycled by qualified and authorised companies.

The plastic materials may cause environmental damage, therefore they should be handed over to specialised companies authorised for disposal.

The disposal of the packaging must be carried out in accordance with the regulations in force.

## 8. TROUBLESHOOTING

The maintenance interventions authorised by **Duplex International S.r.l.** are indicated in chapter **"7. MAINTENANCE"**.

The content of this chapter is not exhaustive. Instead, it aims to provide information on the most common problems in order to help specialised technicians to find the fault in question.

### CAUTION

The indications under the term **"SOLUTION"** in the tables below **DO NOT AUTHORISE** interventions that could jeopardise safety.



PROBLEMS	PROBABLE CAUSE	SOLUTION
<b>Wet stripes on the sides</b>	Excessive liquid dispensed.	Dispense less liquid.
	Irregular paths are covered failing to follow the instructions on paragraph <b>"6.4 How to wash floors"</b> .	Follow the instructions in chapter <b>"6.4 How to wash floors"</b> .
	Rest Traslation switch in transport position.	Move the Rest Traslation switch to the required position.
	Recovery tank scrapers are dirty or worn.	Clean or replace the scrapers.
<b>The dirt is not picked up</b>	Mop-Up device turned off.	Turn on the Mop-Up device.
	Recovery tank with dirty or worn scrapers.	Clean or replace.
	Worn brushes.	Replace.
	Cleaning liquid not coming out.	Check the valve and adjust the screw under the handle lever.
<b>Does not start up</b>	The recovery tank is not properly seated in its housing.	Check and insert the recovery tank correctly.
	Power cord faulty or plug not correctly inserted into the socket.	Restore and replace, if necessary.

	Power cord tripped.	Replace.
	"Motor Protector" tripped	Reset the appliance and re-activate it by pressing the <b>MP</b> (Motor Protector) button. Reactivation occurs after approximately 6 seconds of it being pressed.
<b>Does not start up</b>	Brush pressure regulator in Reset Translation position.	Move the pressure regulator to the required position.
	Faulty motor.	Contact the Manufacturer.
	Voltage too low.	Contact the mains provider.
	Start-up capacitor tripped or in short circuit.	Replace.
<b>Vibrations during the work stages</b>	Brushes dirty or deformed	Clean or replace.
<b>Liquid flows continuously</b>	The feelers have not gone back into position and prevent the tanks from being removed. As a result, the valves remain open.	Pull the lever on the handle several times in order to facilitate the unblocking. Otherwise introduce a screwdriver or a piece of wood into the opening of the tank and press on the rubber valve so that it pushes the feelers backwards.
<b>The liquid flows out even if the feelers have been retracted.</b>	The valves in one of the tanks are blocked.	Press the valves several times to unblock them.
	A foreign body has been caught up in the valve seat.	Rinse each tank vigorously while keeping the external button that opens the valve pressed down.
<b>The steam generator does not produce steam</b>	No water in the water tank with filter.	Fill
	Faulty pump	Replace.
	Steam nozzles clogged with limescale	Descale

