

# Use and maintenance manual

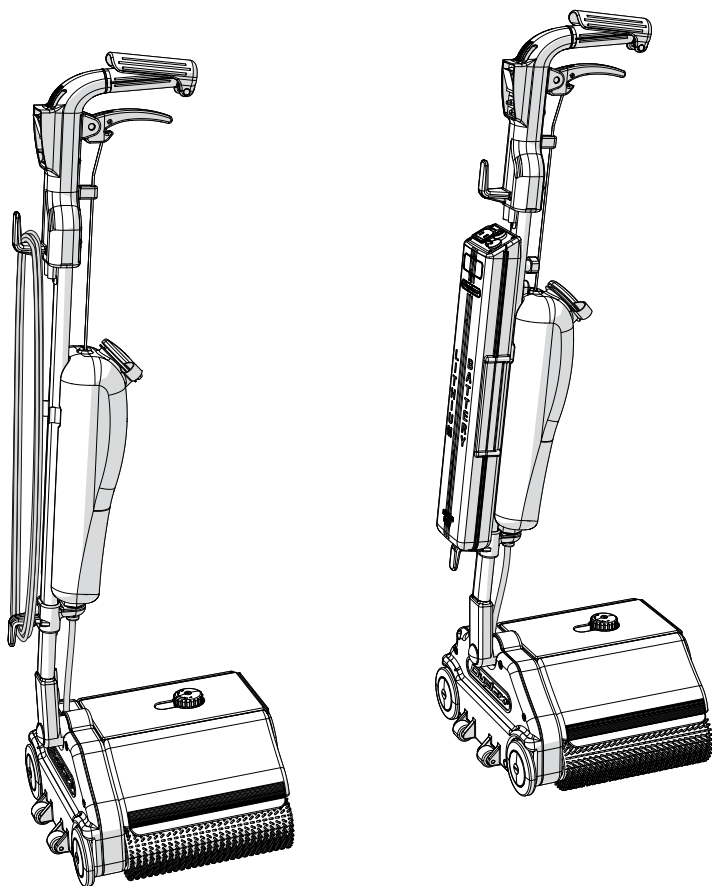

## FLOOR AND CARPET CLEANER



**DUPLEX 280**  
**DUPLEX 280**

EN

Translation of the original instructions

Rev.  
1.0

# Contents

<b>1. PURPOSE AND CONTENT OF THE MANUAL</b>	<b>5</b>
1.1 Symbols	5
1.2 Purpose of the manual	5
1.3 Conservation	6
1.4 Updating the manual	6
1.5 Confidentiality	6
1.6 Recipients	6
<b>2. GENERAL INFORMATION</b>	<b>7</b>
2.1 Manufacturer identification data	7
2.2 Liability limitations	7
2.3 Identification plate	8
2.4 Reference standards and conformity:	9
2.4.1 Declaration of conformity	10
2.5 Warranty	11
2.5.1 Forfeiture of the warranty	11
<b>3. GENERAL SAFETY INSTRUCTIONS</b>	<b>13</b>
3.1 Residual risks	13
3.2 General requirements	14
3.3 Electrical hazards	15
3.3.1 Power cord (DUPLEX 280i AC)	15
3.3.2 Lithium battery (DUPLEX 280i DC)	15
3.4 Safety signs	17
3.5 Noise level	18
3.6 Vibration level	18
<b>4. TECHNICAL CHARACTERISTICS</b>	<b>19</b>
4.1 General description	19
4.1.1 Proper and improper use	19
4.2 Description of the components	20
4.2.1 Technical data	22
4.3 Brushes	23

4.4 Lithium battery (DUPLEX 280i DC only).....	24
4.4.1 Storing for a long period of time.....	25
4.5 Type of detergents .....	26
<b>5. ASSEMBLING THE APPLIANCE _____</b>	<b>27</b>
5.1 Packing contents .....	28
5.2 Assembling the handle.....	30
5.2.1 Disassembling the handle .....	30
5.3 Fitting the battery (DUPLEX 280i DC only) .....	31
<b>6. OPERATION AND USE _____</b>	<b>33</b>
6.1 How to use .....	33
6.1.1 Filling the tank .....	33
6.1.2 Recovery tank.....	34
6.2 Charging the battery (DUPLEX 280i DC only) .....	36
6.2.1 Charge level of the battery (DUPLEX 280i DC only).....	37
6.3 Switching on system of the DUPLEX 280i AC .....	38
6.4 Switching on system of the DUPLEX 280i DC.....	39
6.5 Starting up the appliance .....	40
6.6 Motor Protector .....	41
6.7 Instructions on how to clean surfaces.....	42
6.7.1 Bi-directional cleaning system .....	42
6.7.2 Work stages .....	43
6.7.3 Cleaning carpets or rugs .....	44
6.7.4 How to clean Parquet floors.....	44
6.7.5 Cleaning flooring.....	44
6.7.6 Cleaning flooring with WAX CLEANERS.....	44
6.7.7 Cleaning of heavily dirty, hard or dingy flooring.....	46
6.8 Stopping the appliance.....	47
6.9 Transport.....	48
<b>7. MAINTENANCE _____</b>	<b>49</b>
7.1 Cleaning .....	49
7.2 Brush maintenance.....	51
7.2.1 Replacing the brushes .....	52
7.2.2 Cleaning the brushes .....	52

7.3 Replacing the scrapers.....	53
7.4 Conveyor belts .....	53
7.5 Power cord (DUPLEX 280i AC only) .....	54
7.6 Routine maintenance table .....	55
7.7 Disposal .....	56
7.7.1 Differentiation and sorting of the materials .....	56
7.7.2 Disposing of the battery (DUPLEX 280i DC only).....	57
<b>8. TROUBLESHOOTING _____</b>	<b>59</b>

# 1. PURPOSE AND CONTENT OF THE MANUAL

## 1.1 Symbols

To ensure the safety of persons and property, this manual contains special symbols which draw attention to particularly dangerous situations, warnings and important information:

**HAZARD!**

Hazard with a risk of injury or even death.

Accident prevention regulations for the operator.

**PAY THE UTMOST ATTENTION TO TEXT BLOCKS INDICATED BY THIS SYMBOL.**

**ELECTRICAL HAZARD!**

Hazard with a risk of injury or even death.

Accident prevention regulations for the operator.

**PAY THE UTMOST ATTENTION TO TEXT BLOCKS INDICATED BY THIS SYMBOL.**

**WARNING!**

Possibility to cause damage to the appliance and/or its components.  
Be careful.

**WARNING!**

Warning or remark on key functions or useful information on the operation in progress.

## 1.2 Purpose of the manual

This user manual is an integral part of the appliance and must be kept in its entirety and within the user's reach for the whole working life of the appliance.

The manual contains information on safety, technical aspects, operation, maintenance and spare parts. Its purpose is to provide the customer with the necessary information to use and control the appliance correctly, independently and safely.

**CAUTION**

**Read this manual carefully and observe the instructions provided before using, testing and operating the appliance.**

### 1.3 Conservation

The manual must be kept with care and near the appliance, protected from liquids and other substances that could compromise its readability and it **must be readily accessible at any moment**.

The manual and the Declaration of conformity are integral parts of the appliance, and therefore, they must accompany it during its whole working life.

### 1.4 Updating the manual

The information, descriptions, and illustrations contained in this manual reflect the state of the art at the moment of machine sale.

The Manufacturer, committed to the constant improvement of their products and/or for market reasons, reserves the right to make technical or commercial modifications to the appliances at any given moment without prior notice.

Any additions must be retained together with the manual and are to be considered integral parts of the manual.

### 1.5 Confidentiality

The technical information (text, drawings and illustrations) provided in this manual is property of **DUPLEX INTERNATIONAL S.r.l.** and must be considered confidential.

It is strictly forbidden to disclose, reproduce or translate this document, even partially this document, unless authorised in writing by **DUPLEX INTERNATIONAL S.r.l.**

### 1.6 Recipients

This manual is addressed to personnel assigned to use the appliance for cleaning floors and carpets.

---

#### HAZARD!



**The appliance must not be used by children or persons with reduced physical, mental or sensory capacity, or lacking in experience and knowledge in the use of the appliance, unless they are supervised or instructed on the use of the appliance by persons responsible for their safety.**

**Children should be supervised to ensure that they do not play with the appliance.**

---

## 2. GENERAL INFORMATION

### 2.1 Manufacturer identification data

#### DUPLEX INTERNATIONAL Srl



Via Gobetti, 19-21-23  
50058 SIGNA - FLORENCE  
ITALY



Phone: +39 055 876437



Fax: +39 055 875229



Website: [www.duplexitaly.com](http://www.duplexitaly.com)



Email: [infoduplex@duplexitaly.com](mailto:infoduplex@duplexitaly.com)

### 2.2 Liability limitations

The manufacturer declines all liability for damage to persons or property caused by:

- Improper use of the appliance.
- Total or partial failure to comply with the given instructions.
- Appliance use not complying with the regulations in force.
- Use not complying with national laws on safety and accident prevention.
- Tampering with even one single part of the appliance.
- Incorrect installation and/or connection to the foreseen power sources.
- Use of non-original spare parts.

## 2.3 Identification plate

A plate **1** bearing the essential identification data for any assistance or spare parts request is applied to the appliance. The plate contains the following data:

- A) Model
- B) Serial number
- C) Year of manufacture
- D) Weight



### CAUTION

Do not remove the identification plate for any reason.  
Please contact the Manufacturer in the event the identification plate gets damaged.

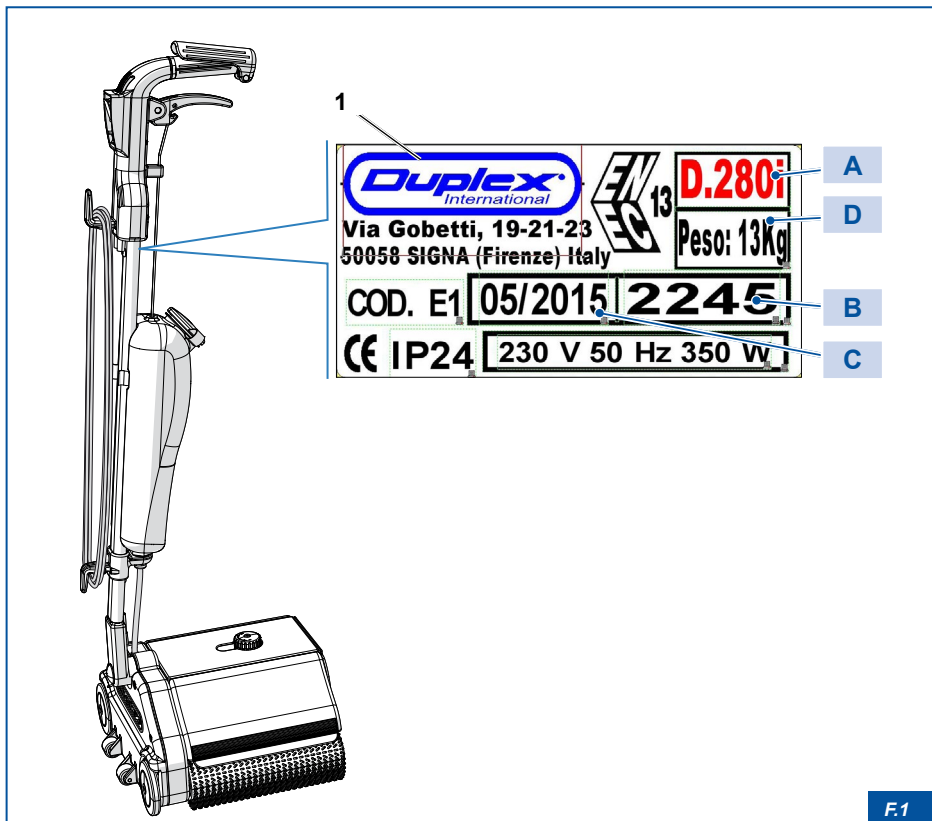

F.1

## **2.4 Reference standards and conformity:**

### **STANDARDS:**

**EN 55014-1:06 + A1:09 + A2:11,  
EN 55014-2:15  
EN 60335-1:12 +A11:14,  
EN 60335-2-67:09,  
EN 61000-3-2:14,  
EN 61000-3-3:13,  
EN 62233:08**

**In compliance with the following provisions and Directives 2004/108/EC (EMC),  
2006/42/EC (MD)**

## 2.4.1 Declaration of conformity

The EC Declaration of Conformity, provided together with the appliance, is the document with which the Manufacturer certifies, under its own responsibility, the observance of the required European Directives, Standards and Technical Specifications (specified in the Declaration) in order for the appliance to comply with the basic requirements for sale and use in the European Union.

The Declaration of conformity must be considered an integral part of the appliance and must always accompany the appliance until it is scrapped.



### WARNING

**If the declaration of conformity is not delivered together with the appliance or gets lost, please request a copy from the Manufacturer.**



Lavapavimenti-Lavamoquette-Lavascala e tappeti mobili  
Floorwasher-Carpetwasher-Escalator Cleaner

**EG-KONFORMITÄTSERKLÄRUNG  
EC-DECLARATION OF CONFORMITY  
CE-DÉCLARATION DE CONFORMITÉ  
CE-DICHIARAZIONE DI CONFORMITÀ**

**Wir/We/Nous/Noi**  
Duplex International S.r.l.  
via P. Gobetti 19  
IT-50058 Signa (FI)

er klären in alleiniger Verantwortung, dass das Produkt  
declare under our sole responsibility that the product  
dichiaro sotto nostra esclusiva responsabilità che il prodotto  
dichiariamo sotto la nostra esclusiva responsabilità che il prodotto:

Floor and Carpet Cleaner Mod. Duplex 280i AC

auf das sich diese Erklärung bezieht, mit dem folgenden Normen-Übersicht  
to which this declaration relates is in conformity with the following standards  
auquel se réfère cette déclaration est conforme aux normes  
al quale si riferisce la presente dichiarazione è conforme alle norme

EN 5036:03 + A1:06, EN 55014-1:05 + A1:09, EN 55014-2:07 + A1:01 + A2:08,  
EN 60335-1:02 + A1:04 + A1:10 + A2:06 + A1:05 + A1:09, EN 60335-2-97:09,  
EN 61000-3-2:06 + A1:09 + A2:09, EN 61000-3-3:08, EN 61223:08

gemäß den Bestimmungen folgender Richtlinien  
following the provisions of Directives  
conformément aux dispositions des Directives  
conformemente alle disposizioni delle Direttive

2004/108/EC (EMC), 2006/95/EC (LVD)

Sign: (Firma) 01 Aprile 2015  
Sig.ra Patrizia Scarselli / Amministratore Unico

.....

Verantwortlich für die technische Dokumentation ist:  
Responsible for the technical documentation is:  
responsable pour le documentation technique est:  
Il responsabile della documentazione tecnica è:  
Mr. Mauro Querci

SEV Association for Electrical Engineering, Power and Information Technologies  
Lugonesinause 1 Tel. +41 44 86 11 11  
CH-6300 Fribourg Fax +41 44 86 11 22  
info@electroussa.ch

F.2

## 2.5 Warranty



### WARNING

The commercial warranty issued by the seller has a validity of **“24 months”**.

Warranty acknowledgement can be obtained by showing a photocopy of the receipt or invoice along with the appliance serial number.

Failure to send this document entails the non-acknowledgement of the warranty.

The warranty does not cover expendable components such as:

- Brushes;
- Scrapers;
- Conveyor belts;
- Power cords on the appliance;
- Safety handle and its switch;
- The two large transfer wheels;
- The two small wheels and their casing to which they are fastened.
- Plastic or metal parts damaged out of negligence.
- Lithium-ion battery.
- Battery charger.

### 2.5.1 Forfeiture of the warranty

The warranty will be void in the following cases:

- The appliance is used for purposes not complying with those for which it has been designed or is used improperly.
- Failure to observe the indications for use described in the manual.
- The appliance is damaged by the use of unsuitable or inadequate aggressive and highly acid chemical products such as: static dissipative detergents, hydrochloric acid, trichloroethylene, methyl ethyl ketone, acetone, pure ammonia, bleach or pure sodium hypochlorite, etc.

### 3. GENERAL SAFETY INSTRUCTIONS

This chapter gives the necessary information on how to use the appliance fully complying with the safety regulations in force.



#### CAUTION

The manufacturer declines all responsibility for any damage to property and/or persons caused by the failure to comply with the instructions provided in the following Chapter.



#### WARNING

**Being familiar with the main safety standards and regulations is an essential requirement for using the appliance accordingly.**  
The operator should observe the safety regulations in force in the country in which the appliance is being used.



#### HAZARD!

**Follow all safety instructions indicated in this chapter for a safe use of the appliance.**

#### 3.1 Residual risks

Residual risks are the risks that remain despite all safety measures were taken, as well as potential non-evident risks.

To avoid hazards to persons or damage to the appliance caused by residual risks, follow the instructions provided in this manual.

Wait for the complete stop of all moving devices and/or the complete cooling of components subject to heating before carrying out any intervention on the appliance.

Follow the indications and warnings indicated on the signs applied to the appliance and/or to its components.

## 3.2 General requirements



### CAUTION

**Read this manual carefully and observe the instructions provided before using, testing and operating the appliance.**

To avoid hazards to persons or damage to the appliance, follow the instructions and the code of conduct indicated below:

- The appliance was designed and constructed exclusively to clean floors. Any other use is considered improper.
- The appliance can be exclusively used by authorised and trained personnel.
- The appliance must not be used by children or by persons of reduced physical, mental or sensory capacity, or lacking in experience and knowledge in the use of the appliance, unless they are supervised and instructed on the safe use of the appliance by persons responsible for their safety.
- Children should be supervised to ensure that they do not play with the appliance.
- Unplug the power cord plug from the power socket or battery before performing any maintenance intervention.
- Do not use the appliance if you notice any irregularities in its operation.
- In the event of a fault, have the appliance repaired exclusively by qualified technicians.
- Use only original spare parts.
- Do not pour water or liquids directly onto the appliance.
- Do not use acid-based detergents that could damage the appliance.
- Do not mix together detergents of different types to avoid the emission of harmful gases.
- Do not use the appliance to collect hazardous dusts.
- Be careful not to hit shelves or scaffolds when using the appliance to avoid objects falling down.
- Do not use the appliance to clean uneven surfaces or surfaces with many holes.
- Do not use the appliance in potentially explosive environments or areas exposed to hazardous substances or under unsuitable microclimatic conditions.
- Do not use the appliance under inclement weather conditions.
- Do not clean surfaces contaminated by flammable liquids.
- Switch off the appliance immediately after its use.
- Ensure the appliance does not sit on the brushes when it is in its rest position, but that it is supported and raised by the tripod.  
If this not the case, the appliance weight could warp the brushes.
- Store the appliance in a closed and dry place after use.
- Do not modify or tamper with the appliance.
- Do not remove the guards.
- Use only brushes supplied with the appliance or those specified in the instruction manual.

- Use personal protective equipment (PPE) suitable for the work to perform.
- Use a powder extinguisher in case of fire. Do not use water.

### 3.3 Electrical hazards



#### **ELECTRICAL HAZARD!**

**Do not perform any type of intervention on live equipment (maintenance, cleaning, etc.).  
Disconnect the power supply (battery or power cord) before any intervention on the appliance.**

#### 3.3.1 Power cord (DUPLEX 280i AC)

- Regularly check that the power cord is intact and does not show signs of wear, cracking or peeling.
- If the power cord is damaged, replace it before using the appliance.
- Use a cable of the same type used by the Manufacturer, certified according to “ENEC” European standards.
- Cable replacement must be performed by qualified personnel.
- Do not use the appliance if the power cord or plug are damaged or if the appliance fell to the ground or got damaged in any way.
- Do not immerse the appliance, its power cord or plug in water or any other liquid.
- Avoid any contact of the power cord with the brushes.
- If the power cord gets caught under the appliance brushes: STOP the appliance immediately. Do not try to remove the power cord when the appliance is running. Replace the cable if damaged.
- Do not pull on the cable to unplug the plug from the power socket.

#### 3.3.2 Lithium battery (DUPLEX 280i DC)

- Use battery chargers that comply with the technical specifications of the battery.
- Use the battery charger exclusively to charge the battery.
- Unplug the appliance before removing the battery.
- The battery and the battery charger must be disposed of correctly, following the national regulations in force. The Customer is legally responsible for dangers generated during battery disposal.
- Do not immerse the battery in water or sea water.
- Do not burn or heat lithium batteries as they could explode or blow up violently.
- Do not try to start up the appliance when the battery is flat.
- Do not use battery chargers different from that supplied by the Manufacturer.
- Do not expose the battery to direct sunlight.

- Keep the battery away from heat sources: radiators, heaters, stoves, mantelpieces, etc.
- Do not try to open the special battery fireproof plastic enclosure.
- Do not break, open or pierce the battery package.
- Do not weld or pierce the battery using a needle or other sharp objects.
- Do not weld cables on the ends of the batteries.
- Do not short circuit the battery positive and negative terminals.
- Do not invert the positive and negative terminals during use.
- Do not connect the battery electrodes to an electrical output.
- Do not touch the electrodes with parts of your body or metal objects.
- Stock and store the battery in a cool and dry place.
- Do not transport or store the battery together with metal objects, as for example: hair pins, necklaces, etc.
- Do not hit, tread on or throw the battery.
- Do not disposed of the battery improperly.

### 3.4 Safety signs

The appliance is equipped with plates and pictograms drawing the attention in a fast and easy way to objects and situations that can cause certain hazards, and in particular:

- Prevent dangerous behaviours;
- Warn the exposed persons of a risk or hazard;
- Prescribe safe behaviours;



#### HAZARD!

It is strictly prohibited to remove the safety signs or alter their characteristics.

Check that the safety signs are always perfectly legible;  
Replace damaged signs with other of the same type and make sure to apply them in their original positions.

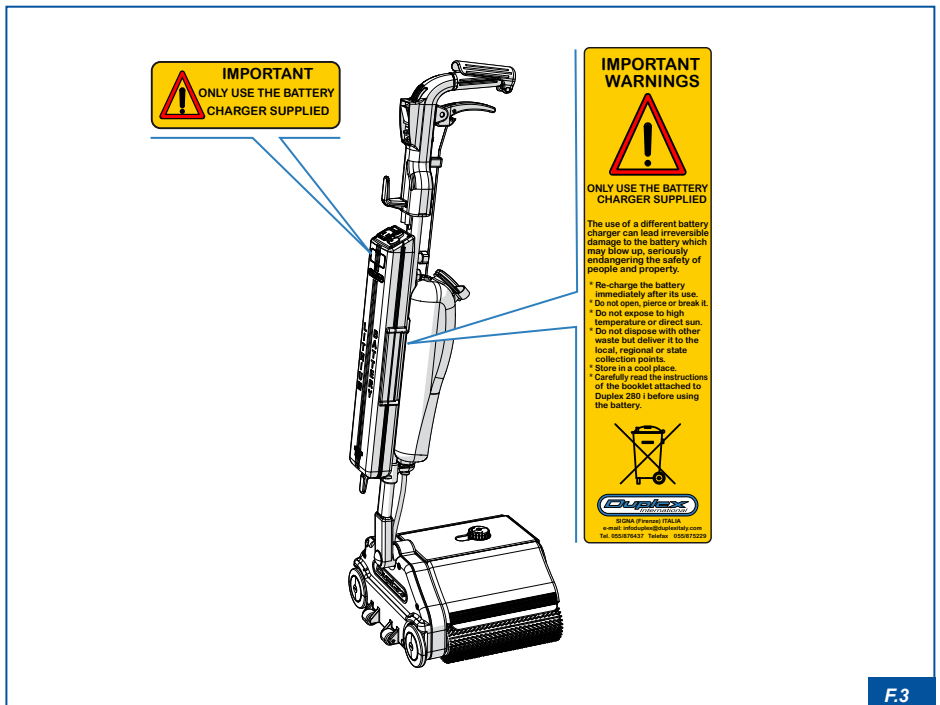

F.3

### 3.5 Noise level

The appliance was designed and constructed in such a way to minimise the noise emitted during its normal operation.

The sound pressure level weighted and generated by the appliance's various components is <72,8 dB (A). It was measured at the operator's ear during the normal work cycle and following the criteria set forth by the regulations in force.

The sound pressure level may vary considerably according to the work environment.



#### **WARNING**

**Use appropriate personal protective equipment if you suffer a constant discomfort due to the noise produced by the appliance.**

### 3.6 Vibration level

The appliance was designed and constructed in such a way to minimise the level of vibrations generated during its normal operation.

The whole body vibration level weighted and generated by the appliance's various components is 0,95 m/s<sup>2</sup>

## 4. TECHNICAL CHARACTERISTICS

### 4.1 General description

The **Duplex 280i** was designed and constructed to be used to clean floors and carpets. During its design and construction, all necessary measures were taken to produce a high-quality, reliable product, fully compliant with the regulations in force and with particular regard to accident prevention.

This compact appliance is perfect for small rooms as it is able to reach even the most narrow places.

This is achieved by means of its two-way handle that allows you to change the cleaning direction by simply reversing the handle.

Constructed using aluminium casings, it ensures that each of its components is sealed and leak-tight, preventing any infiltration of water and dust. The appliance is fitted with a safety handle to switch it on and off promptly.

#### 4.1.1 Proper and improper use



##### **HAZARD!**

**It is strictly prohibited to use the appliance under different conditions than those described in this manual. Any other different use of the appliance is not authorised and is dangerous (improper use).**

---

The selection of the materials used to manufacture the appliance was assessed according to the specific use for which the appliance is intended. Improper use can cause damage to persons and/or property and jeopardise its correct operation.

The observance of the use, repair and maintenance instructions described in this manual, is an essential requirement to use the appliance correctly.

The use of the appliance for activities not foreseen during its design and which are not listed in this manual, shall relieve the Manufacturer of any direct or indirect liability.

Any arbitrary alteration made to the appliance shall relieve the Manufacturer of any liability for damage or personal injuries, even serious, caused to operators, third parties and/or property.

The correct use of the appliance, the careful observance of the instructions indicated in this manual and the strict application of all requirements to avoid hazardous situations, accidents or injuries, will contribute to making the appliance work better and longer, minimising faults and failures.



##### **CAUTION**

**The Manufacturer declines any responsibility for any damage to property and/or persons deriving from failure to observe the warnings indicated in this manual.**

---

## 4.2 Description of the components

1	Safety handle (Start & Stop)	13	Anti-scratch and non-marking rubber wheels
2	Handle	14	Lithium ion battery
3	Detergent lever	15	Battery charger
4	Anodised rod	16	Support tripod
5	Power cord	17	Motor
6	Tank	18	Motor Protector
7	Liquid detergent hose	19	Battery power socket
8	Cover	20	Safety fuse 15 Amp. mm. 5x20
9	Recovery tank	21	Battery charger socket
10	Brushes	22	Guards
11	Tank knob	23	ON/OFF button
12	Transport rubber wheels		

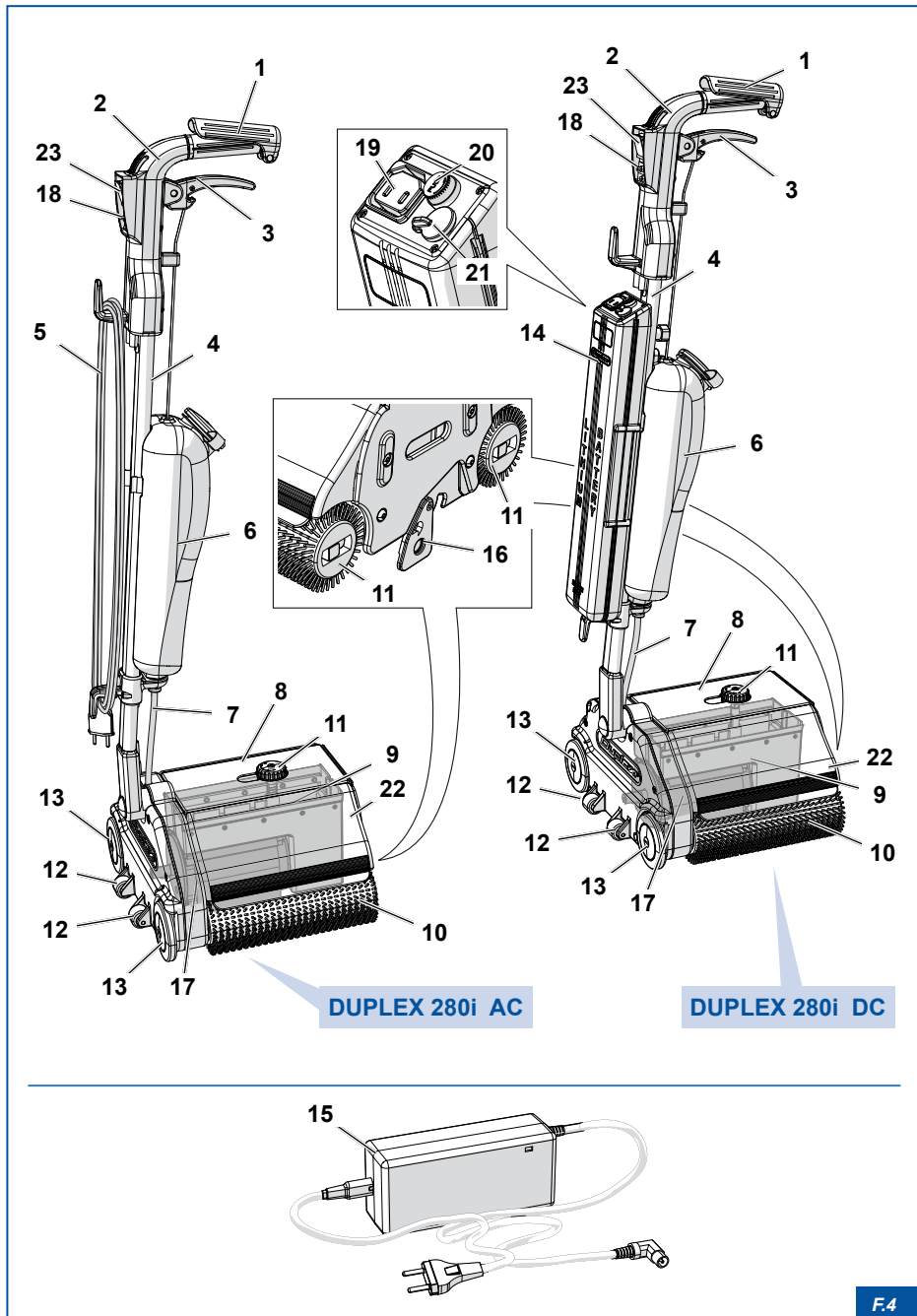

**DUPLEX 280i AC**

**DUPLEX 280i DC**

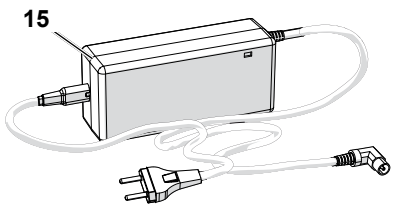

### 4.2.1 Technical data

		DUPLEX 280i AC with power cord		DUPLEX 280i DC with Lithium ion battery
Dimensions: Length - Width - Height	mm	330 x 280 x 105		
Brush diameter	mm	85		
Brush length	mm	220		
Tank capacity	l	1.5		
Recovery tank capacity	l	0.8		
Brushes pressure on flooring	g/cm <sup>2</sup>	200		
Washed track/width	mm	224		
Theoretical working surface	m <sup>2</sup> /h	50/100		
Degree of protection	class	IP24		IP7
Weighted acceleration value	m/s <sup>2</sup>	1.0		
Noise level and vibration	dBA	< 72		
Frequency	Hertz	50/60	60	/
Voltage	Volt	230	115	36
Motor power	Watt	350	350	250
Brush round-minute	rev./'1	650	850	680
Electrical isolation	Class	I°		
Unloaded weight	kg	13.5		11.5

The ENEC certificate is valid only for DUPLEX 280i AC.

		LITHIUM ION BATTERY WITH PROTECTION CARD (PCB)		
Supplied voltage	Volt	36		
Supplied current	Amp.	7.23		
Dimensions Length - Width - Thickness	mm	430 x 85 x 50		
Max. autonomy, with new battery	h	1.15		
Weight	kg	2.3		
SUPPLIED BATTERY CHARGER				
Duplex Universal power supply	Volt	100/240		
Universal frequency	Hz	50/60		

### 4.3 Brushes

The original DUPLEX brushes are tested and balanced individually with special electronic instruments and guarantee the absence of vibrations that could generate mechanical stress for the appliance and the floors.

The brushes can have different colours according to their use characteristics:

<b>Brush colour</b>	<b>Use</b>
<b>GREY</b> (supplied)	All-purpose for light dirt of all types of flooring, smooth or embossed.
<b>BLACK</b> (optional)	Cleaning of very dirty flooring and short pile carpets.
<b>YELLOW</b> (optional)	Cleaning of carpets, rugs or parquet flooring.
<b>BROWN</b> (optional)	Polishing.

## 4.4 Lithium battery (DUPLEX 280i DC only)



### HAZARD!

Read this manual carefully and observe the instructions provided before using, testing and operating the battery and the battery charger. The Manufacturer declines any responsibility for any damage to property and/or persons deriving from failure to observe the warnings indicated in this section or the incorrect use of the battery.



### CAUTION

Use battery chargers that comply with the technical specifications of the battery.



### ELECTRICAL HAZARD!

Do not touch the electrodes with parts of your body or metal objects.



### CAUTION

Do not pour liquids onto the battery and do not immerse the battery in any liquid.

- Do not use or leave the battery exposed to high temperatures as it might overheat, catch fire or jeopardise its operation and duration.
- Do not use the battery in environments characterised by the presence of static electricity or electromagnetic fields. This could damage safety devices and cause dangers.
- If the battery leaks avoid touching it with your skin and eyes.
- Do not charge the battery if the temperature is below 0°C/32°F.



### HAZARD!

In the event your eyes or skin come into contact with the liquids leaked from the battery, rinse with plenty of clean water and seek medical advice immediately.  
**Danger of eye injuries.**

- If the battery present some faults (odd smells, production of heat, warps, etc.) or is not working properly, remove it immediately from the appliance or from the battery charger, dispose of it and replace it with a new one.

- If the battery terminals are dirty, the appliance correct operation might be jeopardised. Clean the dirty terminals before use by means of a dry cloth.
- The battery and the battery charger must be disposed of correctly and safely, following the national regulations in force. The Customer is legally responsible for dangers generated during battery disposal. (See section “7.7 Disposal”).

#### **4.4.1 Storing for a long period of time**

If the battery is stored for a long period of time (over three months), keep it in a fresh and dry place and charge and discharge it every six months.

The storage voltage of the battery must be 3,2~3,35V.

## 4.5 Type of detergents

The appliance can be used with detergents intended for this type of appliance. To use the detergents, follow the detergent manufacturer's instructions relating to the dilution

Do not use unsuitable detergents or aggressive and strong acid-based chemicals like:

- Caustic soda
- Acids
- Diluents
- Solvents



### HAZARD!

**Read the labels on the detergent bottle carefully. Detergents can have harmful impacts on the environment and the human body in case of inhalation, ingestion or contact with skin and mucous membrane. If necessary, use personal protective equipment (PPE) while using detergents.**

---



### CAUTION

**Static dissipative detergents can damage the brushes and plastic parts of the appliance. The manufacturer declines any liability for damage caused to the appliance, flooring of any kind, including carpets and rugs, deriving from the use of non conforming detergents or products.**

---

## 5. ASSEMBLING THE APPLIANCE

For packing and transport purposes, the appliance is delivered disassembled. Check that the packing contents making sure that the appliance's components are all present and in good conditions.



### WARNING

Contact the Customer Service Centre if some components are missing or damaged.



### CAUTION

Follow the instructions contained in this chapter carefully in order to assemble the appliance correctly.

---

## 5.1 Packing contents

Check that the appliance's components inside the packing match those indicated in the table below:

	PACKING CONTENTS	DUPLEX 280i AC	DUPLEX 280i DC
1	Appliance	✓	✓
2	Handle	✓	✓
3	Handle rod	✓	✓
4	Clean water tank	✓	✓
5	Conical inserts, screws, wrench, fuse	✓	✓
6	Instruction manual and inspection sheet	✓	✓
7	Lithium ion battery	-	✓
8	Battery charger	-	✓
9	Battery fastening knob	-	✓

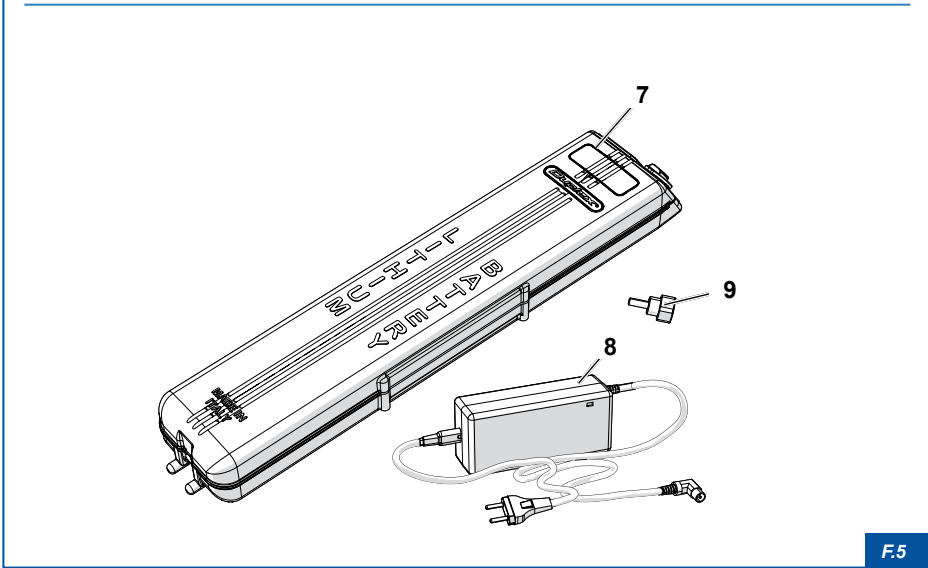
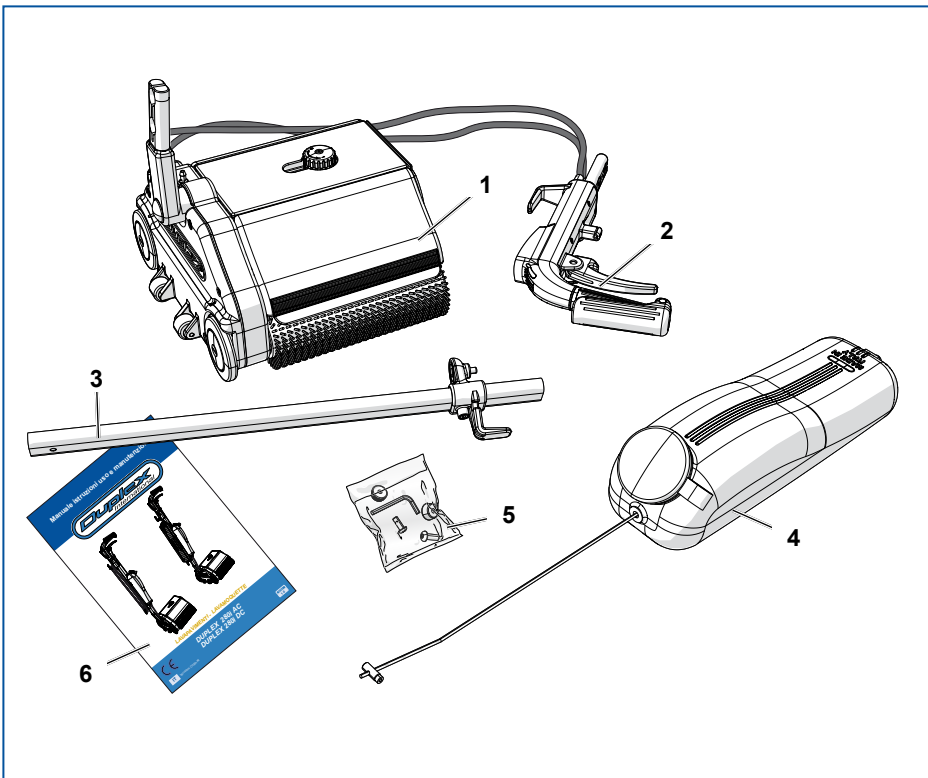

## 5.2 Assembling the handle



### WARNING

Use the supplied hex wrench to assemble the handle as follows:

To assemble the handle, proceed as follows:

- 1) Introduce the conical insert **1** into the seat of the support **2**;
- 2) Insert the anodised rod **3** into the support **2**;
- 3) Fasten the chromed rod **3** using the screw **4** tightening it firmly;
- 4) Place the conical insert **5** into the seat of the handle **6**;
- 5) Insert the handle **6** into the anodised rod **3**;
- 6) Fasten the handle **6** using the screw **7** tightening it firmly;
- 7) Insert the transparent hose **1** for the washing liquid into the appropriate coupling on the appliance casing **9**;
- 8) Fit the tank **10** into the seat of the support **11** inserting it, until it clicks into the anodised rod **3**;
- 9) Couple flexible cable **12** with the lever **13** making it go through the support **14**;
- 10) (for the **DUPLEX 280iAC** model only) Fasten the electrical cable **15** starting from the handle **7** up to the casing, making it go through the appropriate seat of the support **16**.

### 5.2.1 Disassembling the handle



### HAZARD!

Before proceeding with the disassembly operations, make sure that the appliance is disconnected from the mains or battery.

To disassemble the handle, follow the assembly instructions in the reverse order.

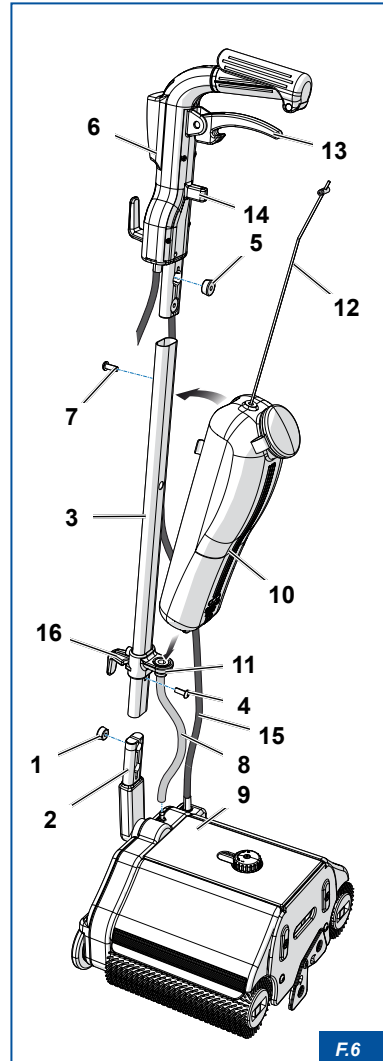

F.6

### 5.3 Fitting the battery (DUPLEX 280i DC only)

Upon first use of the appliance the battery 17 needs to be charged (see section “6.2 Charging the battery (DUPLEX 280i DC only)”).

To fit the battery, proceed as follows:

- 1) Insert the battery 17 on the anodised rod of the handle 3;
- 2) Screw the knob 18 to fasten the battery 17;
- 3) Plug the plug 19 into the battery 17 socket 20.



#### WARNING

If the battery (17) is charged you can start the appliance.



#### ELECTRICAL HAZARD!

Disconnect the appliance from the battery power supply before removing the battery.

To remove the battery, follow the assembly instructions in the reverse order.

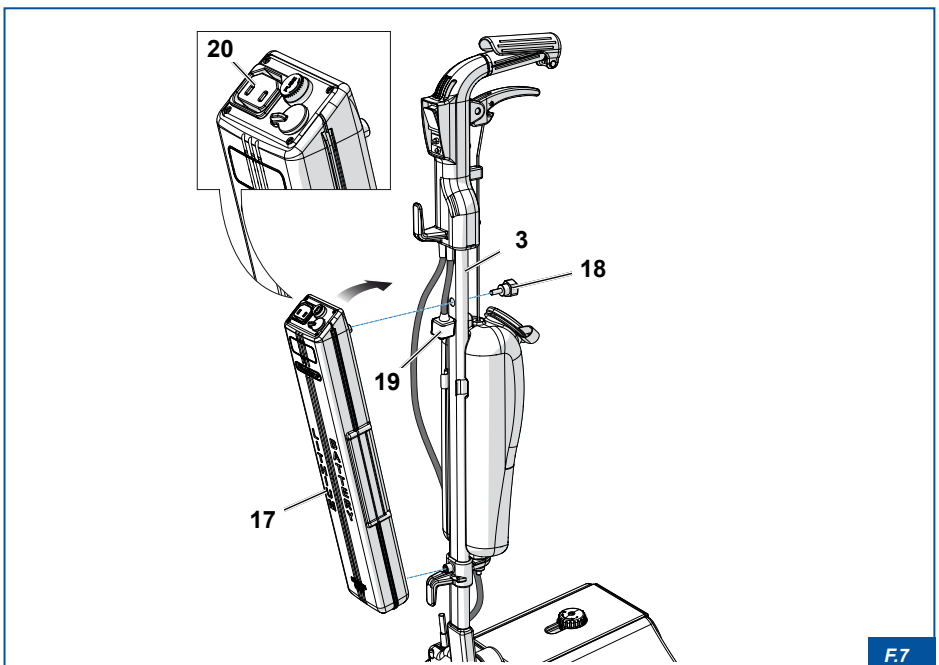

F.7

## 6. OPERATION AND USE



### HAZARD!

Before starting the appliance the operator must have read and understood the instruction manual.

---



### CAUTION

Before starting to clean floors/carpets, choose the most suitable brushes and detergents (see chapter “4. TECHNICAL CHARACTERISTICS”).

---

### 6.1 How to use



### ELECTRICAL HAZARD!

Make always sure that the appliance is disconnected from the mains or the battery (DUPLEX 280i DC), when preparing to operate the appliance.

---

#### 6.1.1 Filling the tank

The removable tank 1 makes the filling up and emptying operations at the end of the job easier.



### CAUTION

Use the detergents indicates in section “4.5 Type of detergents” to avoid damaging the surfaces and the appliance.

---

The tank 1 can be filled in the following ways:

**E) With the tank removed from the appliance:**

- 1) Remove the tank 1 and refill under a water tap.
- 2) Add a non-foaming detergent.
- 3) Stir the solution and re-insert the tank 1 into its housing.

**B) With the tank fitted to the appliance:**

- 1) Mix the detergent with water in a recipient.
- 2) Pour the liquid obtained into the tank 1.

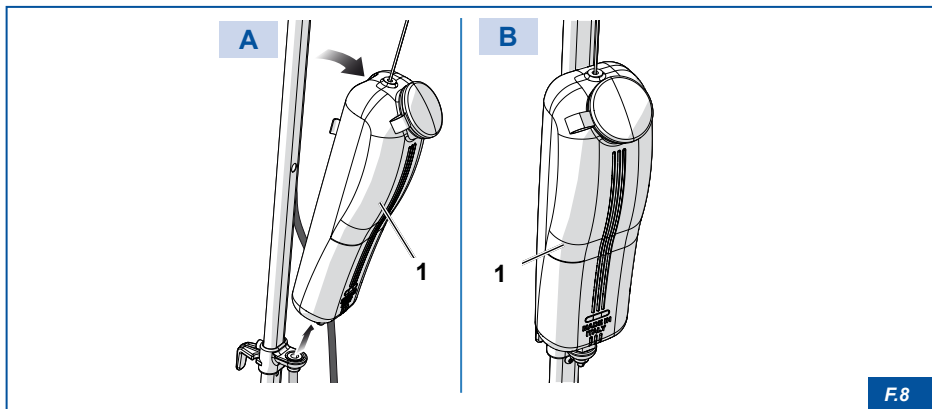

### 6.1.2 Recovery tank

The dirty liquid recovery is achieved by means of the rotation of the brushes 2, which attack the dirt, trapping it and centrifuging it toward the two conveyor belts 3. The dirt accumulated on the active surfaces of the conveyor belts 3 is collected by the scrapers 4 and deposited into the recovery tank 5.

Before starting the appliance, you need to adjust the recovery tank height 5 to allow the dirty liquid to be collected.

- 1) Turn the knob 6 towards the “0” position: the recovery tank 5 lowers and allows the scrapers 4, during the work phase, to collect the dirty liquid by adhering to the conveyor belts 3.
- 2) After using the appliance, turn the knob 6 to “1” to avoid warping the scrapers 4 and the conveyor belts 3 .



**WARNING**

We recommend you to lubricate the rubber conveyors (3) regularly using an ordinary silicone oil spray available in shops.

Once full, the recovery tank 5 must be emptied by removing it from its seat.

3) Remove cover 19.

4) Lift and remove the recovery tank 5 and empty it.



**CAUTION**

The disposal of the dirty water must be carried out in compliance with the regulations in force.

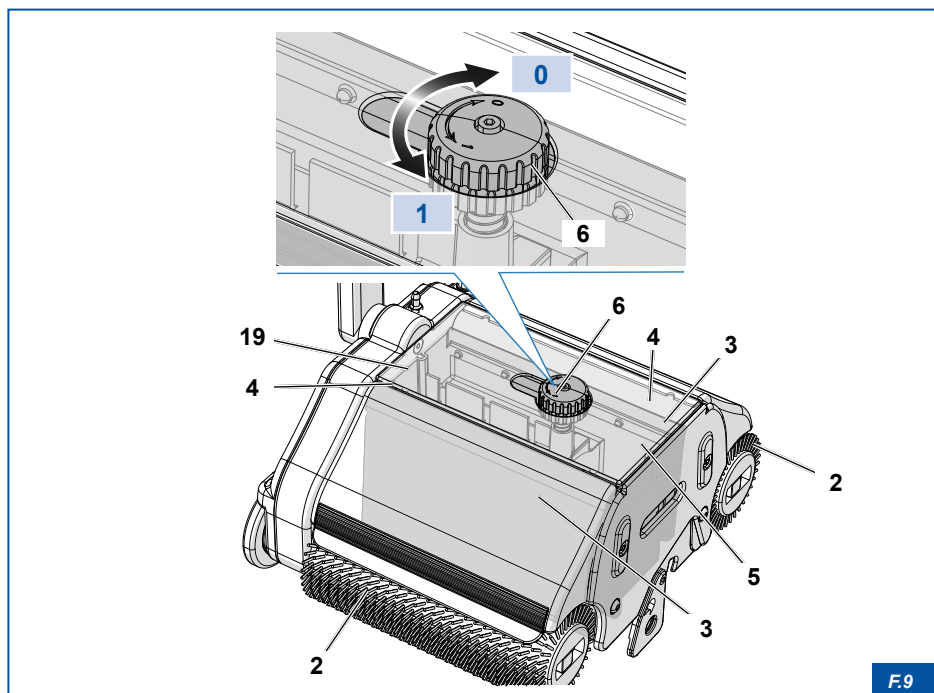

F.9

## 6.2 Charging the battery (DUPLEX 280i DC only)



### HAZARD!

**Do not use battery chargers (7) different from those supplied by the Manufacturer. Doing this, might seriously damage the battery (8) or make it explode violently.**

The lithium ion battery **8** requires a special battery charger **7** supplied with the appliance. The charge lasts about four hours.

When charging is complete, you do not need to remove the battery **8** from the battery charger **7**, as it can be left either inserted into the battery **8** or into the power socket without time limits or problems.

The battery **8** can be charged both removed from the appliance or fitted to it.

In order to charge the battery, proceed as follows:

- 1) Insert the battery charger **7** plug **9** into the charger socket **10**.

When the battery **8** is flat, the LED on the battery charger **7** is red.

When the battery **8** is fully charged, the LED on the battery charger **7** turns green.



### CAUTION

**The battery has an PCB electronic system that readily interrupt appliance operation when its power level is low. Stop the appliance if the PCB does not trigger and you notice a reduction in the brushes' performance.**

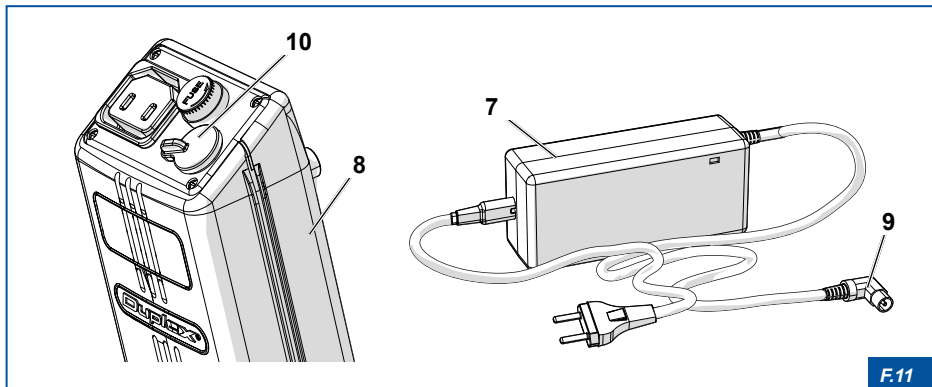

F.11



**HAZARD!**

Do not try to open, pierce or burn the battery container.  
Do not weld the cables at the ends of the batteries.  
Do not short circuit positive and negative terminals.



**HAZARD!**

Do not store, use or recharge the Lithium-ion battery in environments with temperatures above 40°C. This could compromise its durability.  
**Do not leave the battery exposed to sun rays as this can damage it irreparably.**



**CAUTION**

Using and storing the battery in cold places decreases its duration. In this case, the battery power can be restored by recharging it.

If the appliance is not used for long periods of time and is left parked, the battery might self-discharge. Therefore, it needs to be recharged every 40 days.

**6.2.1 Charge level of the battery (DUPLEX 280i DC only)**

The LED 11, according to its colour, indicates the battery charge level:

LED COLOUR	CHARGE LEVEL
GREEN	From 60% to 100%
YELLOW	From 20% to 60%
RED	≤20%

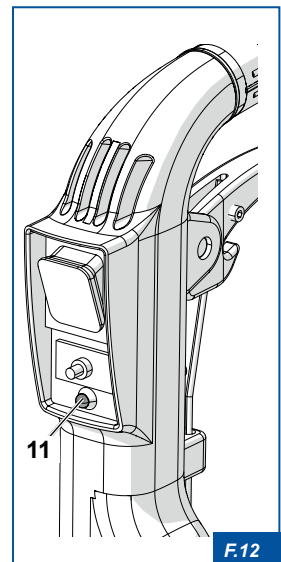

F.12

### 6.3 Switching on system of the DUPLEX 280i AC

- 1) Plug the cable into an earthed socket.



**ELECTRICAL HAZARD!**

**Plug the plug into a compliant and earthed power socket.  
Do not tamper with the earthing.**

- 2) Press the ON switch **12** on the handle **13**. The switch **12** lights up red, indicating that the appliance has switched on.
- 3) Take hold of the handle and press the yellow safety lever **14** to start the appliance.
- 4) Release the yellow safety lever **14** to stop the appliance.



**HAZARD!**

**Pay attention to the power cord.  
We recommend keeping the power cord away from the brushes when  
using the appliance.**

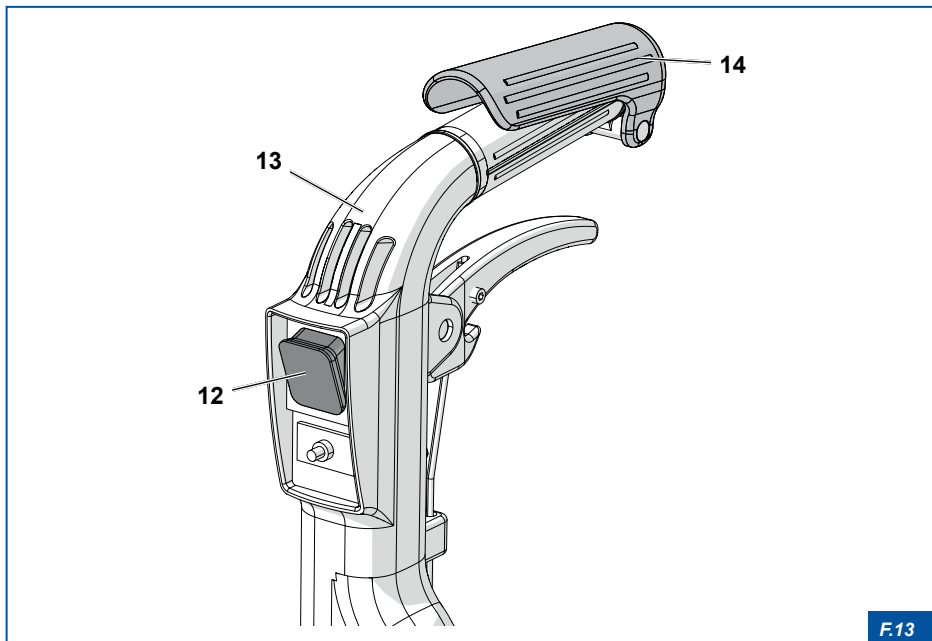

F.13

## 6.4 Switching on system of the DUPLEX 280i DC

- 1) Press the ON/OFF switch **12** on the handle **13**. The switching on of the appliance is indicated by the lighting up of the LED **11** for 60 seconds. Depending on the colour, the LED indicates the battery's charge level.
- 2) Take hold of the handle and press the yellow safety lever **14** to start the appliance.
- 3) Release the yellow safety lever **14** to stop the appliance's motion.



### CAUTION

In the event of interruptions or short work breaks, stop the power flow by turning off the ON/OFF switch (12) to avoid discharging the battery.

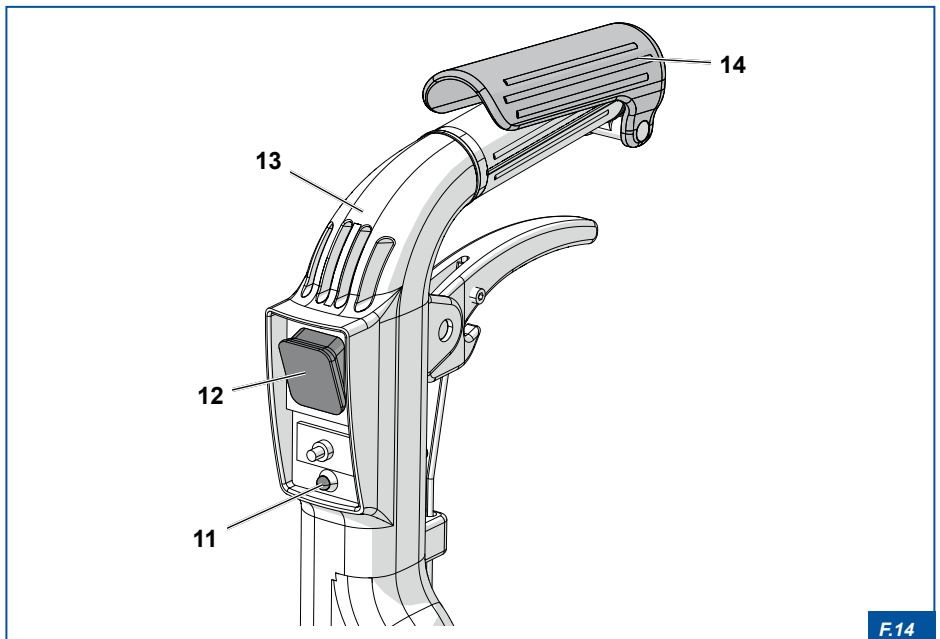

F.14

## 6.5 Starting up the appliance

- 1) Remove the support tripod before starting up the appliance.
- 2) Grab the two-way handle **13** and lower it in one of the two possible directions (**A** or **B**).
- 3) Start the appliance by pressing the yellow safety lever **14**.



### CAUTION

Make sure that you have removed the support tripod (**15**) before use to avoid damaging the appliance.

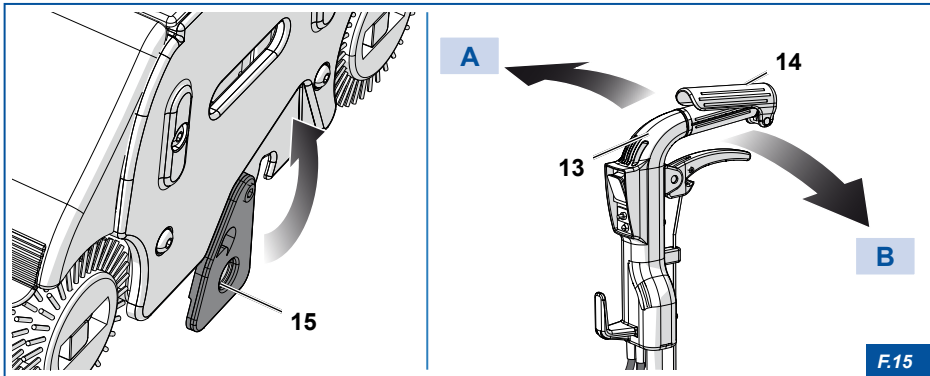

## 6.6 Motor Protector

The “Motor Protector” **16**, is a safety device which stops the appliance in case conditions occur that overload the motor (e.g. foreign bodies caught in the brushes which can prevent their rotation, locking of the brushes for failed start-up due to great friction with the floor, mechanical fault, electric motor fault, poor supply of power, overheating, etc.).

As a sudden stop occurs, the button **16** comes out of its seat and the appliance stops working (figure **A**).

To reset the appliance, proceed as follows:

- 1) Disconnect the appliance from the mains or battery.
- 2) Remove possible foreign bodies stuck in the brushes.
- 3) Connect the appliance to the mains or battery.
- 4) To restart the appliance, press the button **16** two minutes after the occurrence of the stop (figure **B**).



### WARNING

**For the DUPLEX 280i DC model only:**

The sudden stop of the appliance is indicated by the red LED (11) that flashes intermittently until the reset is carried out.

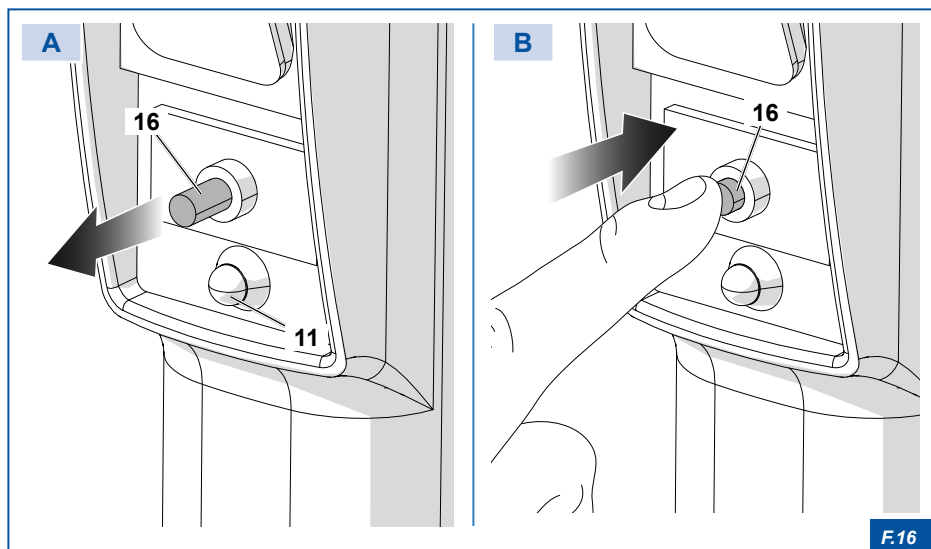

## 6.7 Instructions on how to clean surfaces

Check that the handle is in the rest position (perfectly vertical).  
Switch on the appliance.



### HAZARD!

Carry out the procedures with utmost care to prevent any risk of falling, slipping or collisions. Use personal protective equipment (PPE) if deemed necessary.

### 6.7.1 Bi-directional cleaning system

This system allows the work position to be reversed thanks to the two-way handle **13**. Reversing the handle **13** from right to left and vice versa, allows you to work in both directions and reach the opposite ends of every room, without having to move the appliance.

- 1) Grab the handle, press the yellow safety lever **14** and lower the handle **13** slowly to one side or the other. The appliance will start up and the revolving brushes will start working on the floor.
- 2) Move the appliance slowly forwards following the same cleaning track.
- 3) As the appliance is moving forward, activate the small lever **17** at short intervals to dispense a minimum quantity of washing liquid, taking care not to wet too much and/or flood the floor.

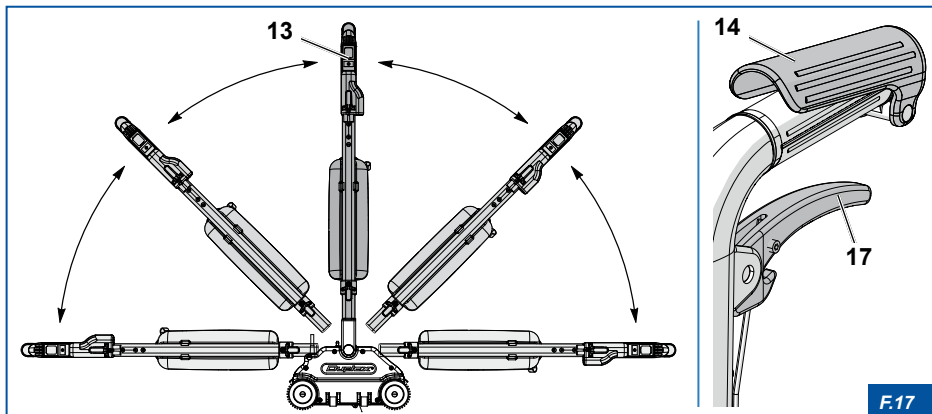

## 6.7.2 Work stages

### Stage 1

- 1) From the starting position, move forward towards the corner as indicated in the figure.
- 2) When you have reached the corner, move back with the appliance and keep cleaning the lane until you reach your starting position.
- 3) From the starting position move to the second lane to wash, slightly overlapping the area you have cleaned before.
- 4) Repeat this operation until you complete stage 1.
- 5) Clean the outer edge on the opposite side of the cleaning area, reversing the appliance.

### Stage 2

- 1) Reverse the appliance cleaning direction using the handle.
- 2) Repeat the operations described in Stage 1.

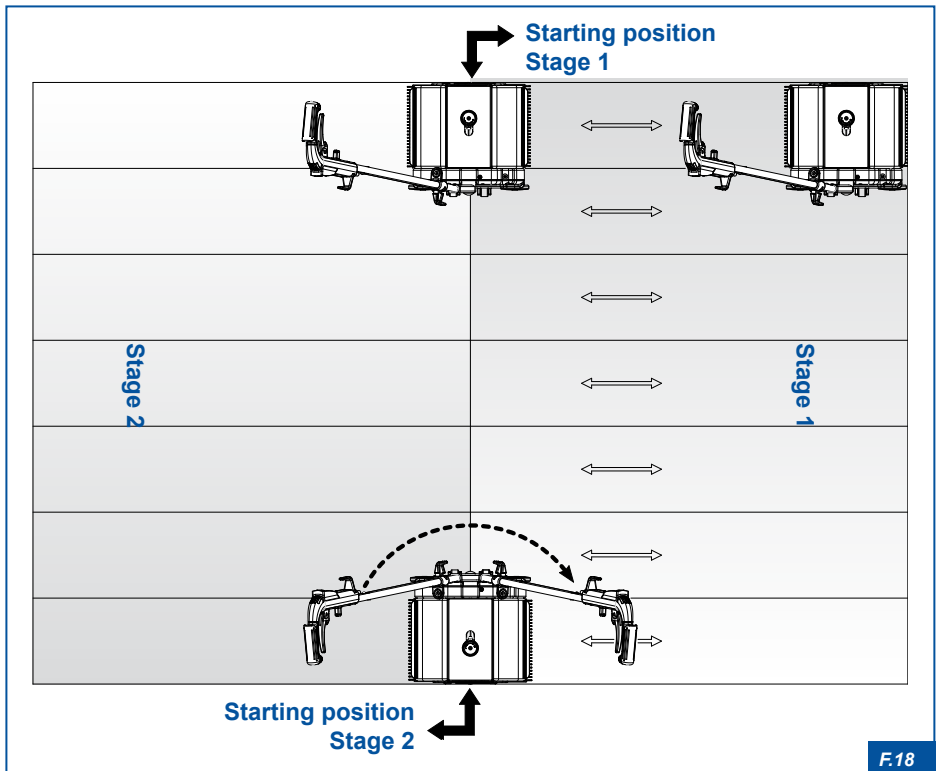

F.18

### 6.7.3 Cleaning carpets or rugs



#### WARNING

**For the DUPLEX 280i DC model only:**

**The lithium ion battery power decreases slightly when brushes face a greater friction cleaning and washing fabric flooring.**

- Fit the yellow brushes (option).
- Use a non-foaming detergent appropriate to clean carpets or rugs.
- Carry out a few tests before starting to wash.
- We advise you to cross the washed tracks so that all fibres appear well cleaned taking care not to wet them too much.

### 6.7.4 How to clean Parquet floors



#### CAUTION

**Be very careful and carry out a few tests before starting to clean. Avoid wetting the floor too much, especially if you need to clean non-painted parquet floors.**

- Fit the yellow brushes (option) or the supplied grey brushes if the parquet is very dirty.
- Use a non-foaming detergent appropriate for parquet flooring.
- Avoid wetting the floor too much, especially in the case of non-painted parquet flooring, which absorbs more moisture.
- Be careful when cleaning this type of floor. Carry out a few tests before washing the entire surface.

### 6.7.5 Cleaning flooring

- Install the supplied grey brushes.
- Use a non-foaming and non-acid all-purpose cleaner (PH max. 9).

### 6.7.6 Cleaning flooring with WAX CLEANERS

Some floors are well suited to be cleaned and treated at the same time with WAX CLEANERS, such as:

- Florentine terracotta tiles
- Smooth tiles
- Clinker
- Marble
- Granite
- Industrial flooring
- Studded rubber flooring
- Wood flooring

- Old wax-treated flooring and many other.

To polish floors, proceed as follows:

- 1) Fit the supplied grey brushes.
- 2) Mix with water any wax cleaner product available (for the dose, follow the instructions on the bottle) and fill the tank.
- 3) Move the appliance forward on the entire surface following the work stages indicated (see section “6.7.2 Work stages”).
- 4) When the work is complete and the floor has dried thoroughly, fit the brown brushes (option) to polish the surfaces.
- 5) Turn the recovery tank knob **6** to “1”, so that only the brushes work and the recovery system is deactivated.
- 6) Move the appliance forward on the entire surface following the work stages indicated (see section “6.7.2 Work stages”).

---

#### WARNING



**Wash the brown brushes (option) after each use to keep them in good working order:**

- Immerse them in lukewarm water and degreasing detergent.
  - Stir and rinse.
  - Use the brushes when they have dried thoroughly.
-

### 6.7.7 Cleaning of heavily dirty, hard or dingy flooring



#### CAUTION

Do not use products that are: “Static dissipative detergents” as can damage the brushes and plastic parts of the appliance.

To clean very dirty or caked flooring, proceed as follows:

- 1) Use an all-purpose concentrated non-foaming and non-acid detergent (pH max. 9).
- 2) Fit the supplied grey brushes for medium dirt or the black brushes (option) for heavy dirt.
- 3) Raise the recovery tank by turning the knob **6** and set it to “1”. In this setting the recovery system will not work and the liquid poured onto the floor will require a more emulsified solution, and therefore, it will allow the detergent to be more effective (soaking).
- 4) Press the lever to dispense a large amount of detergent consisting of product/water, preferably warm at a temperature of 35/40°C.
- 5) Move the appliance forward on the entire wet surface, in all directions or following precise tracks.
- 6) Stop the appliance and turn the knob to “0” to lower the tank and re-activate the dirty water recovery system. Resume moving the appliance forward on the entire wet surface.



#### CAUTION

After cleaning heavily dirty flooring, clean the appliance and brushes very accurately.  
Do not use the dirty appliance to spread the wax.

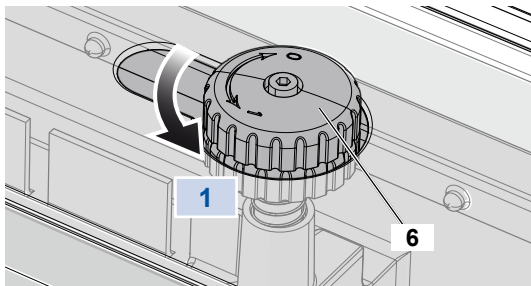

F.19

## 6.8 Stopping the appliance

To stop the appliance, proceed as follows:

- 1) Release the yellow safety lever **14**;
- 2) Move the handle to the vertical position (rest position);
- 3) Press the switch **12** on the handle **13**;
- 4) For the DUPLEX 280i AC model only: unplug the plug from the power socket.

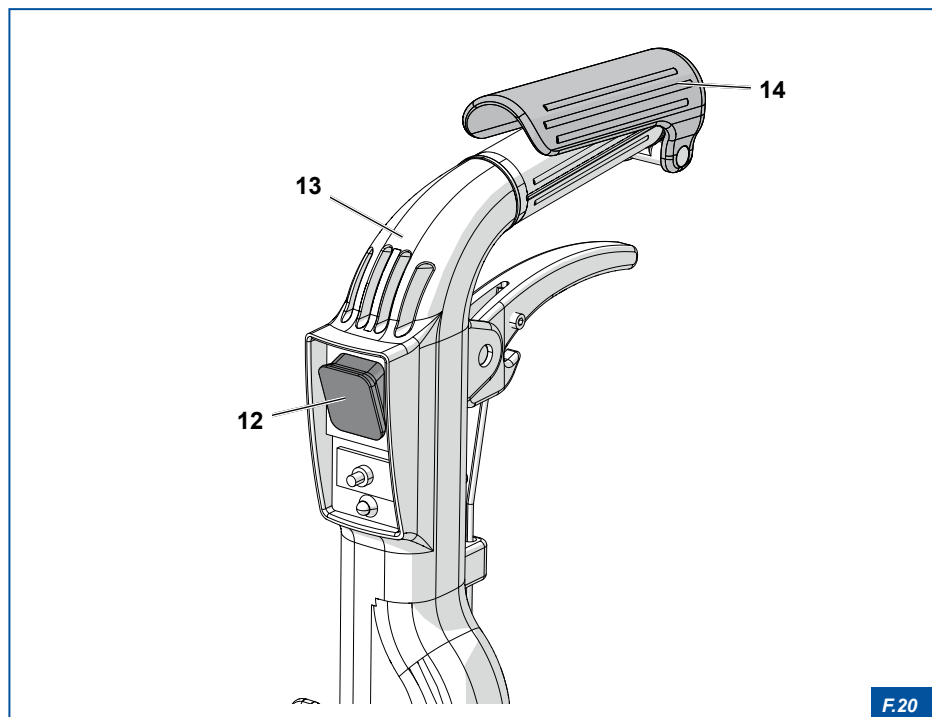

F.20

## 6.9 Transport

The appliance can be moved easily: you just have to tilt it to one side to make it slide on its small rubber wheels **18**.



### HAZARD!

If you have to lift the appliance and you deem it necessary, equip yourself with personal protective equipment (PPE).

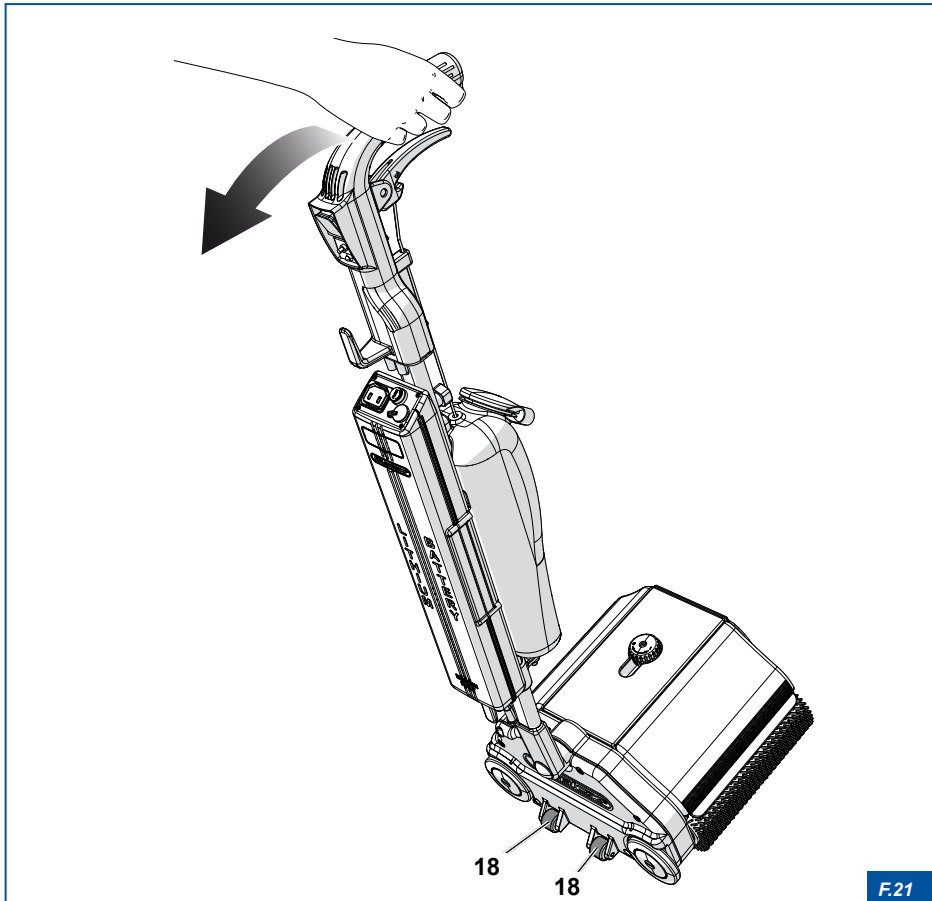

F.21

## 7. MAINTENANCE

We recommend carrying out routine maintenance interventions to keep the appliance in good working order.



### ELECTRICAL HAZARD!

It is absolutely necessary to unplug and disconnect the appliance from the mains or battery before carrying out maintenance, replacement or cleaning operations.

### 7.1 Cleaning



### CAUTION

- Do not use steam jets to clean the appliance.
- Do not use pressurised water jets.
- Do not use corrosive substances.
- Do not use rough, abrasive materials or sharp metal scrapers.



### WARNING

Cleaning operations require just a few minutes and are essential to keep the appliance in good working order at all times.

All mechanical and electrical parts of the appliance are sealed and enclosed in a light alloy casing **1** and do not require maintenance.

The cover **2** fitted with a gasket is fastened with six screws **3**.

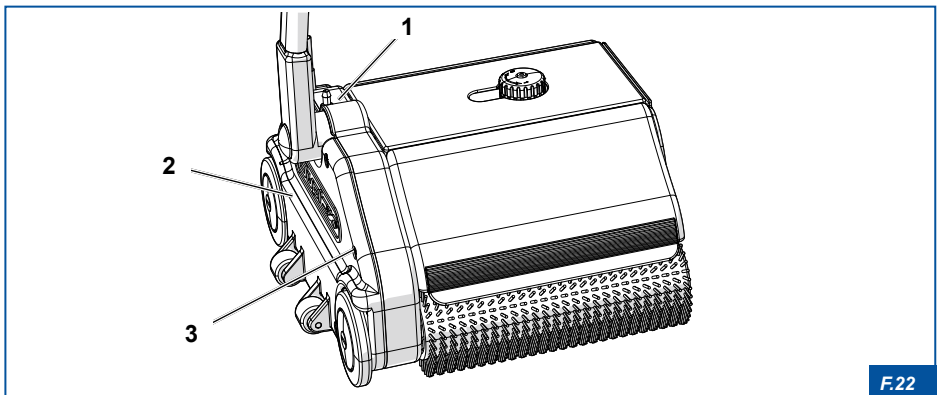

F.22

To clean the appliance, proceed as follows:

**F) DUPLEX 280i AC:** disconnect the power cord plug from the socket.

**G) DUPLEX 280i DC:** remove the battery.

- 1) Remove the cover **4**.
- 2) Remove the recovery tank **5**.
- 3) Remove the two hoods **6** that cover the brushes **7** and wash under running water, preferably using a flat brush. Clean thoroughly all corners and dry.
- 4) Remove the tank **8** on the handle rod, empty it and rinse its interior.
- 5) Remove the brushes **7** and clean them (see section “7.2.2 Cleaning the brushes”).
- 6) Carefully clean the rest of the appliance including the motor using a damp sponge and plenty of water. Dry.
- 7) Refit the recovery tank and turn the knob **9** to “1”;
- 8) Once they have dried, refit all the components removed previously.

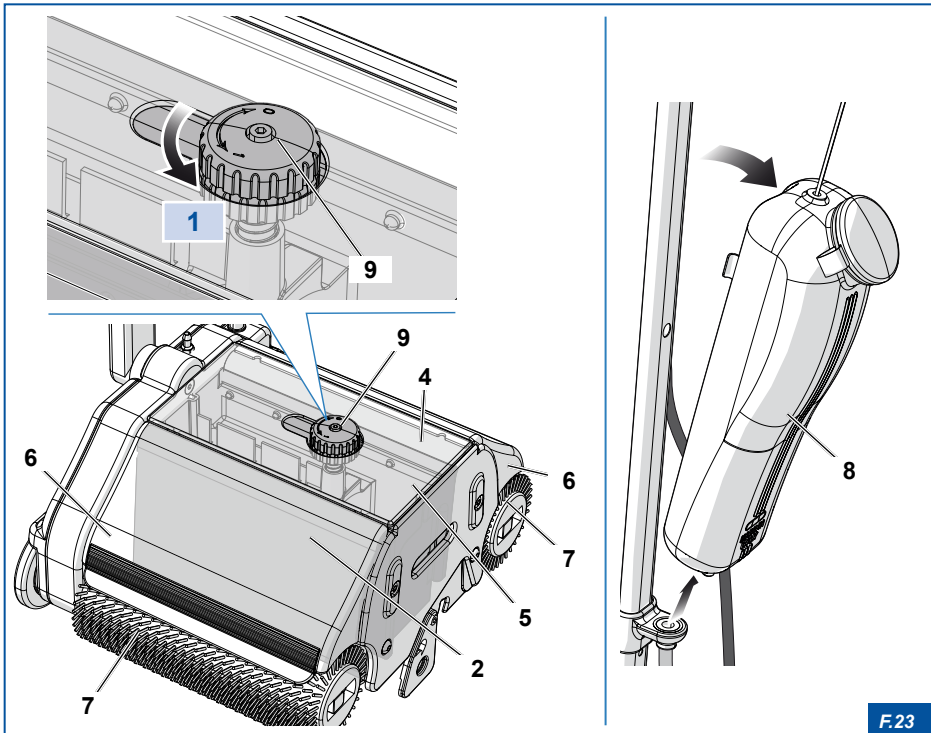

F.23

## 7.2 Brush maintenance

Brushes require little routine maintenance. The high rotation speed during cleaning manages to centrifugate dirt and keep them clean and efficient at all times.  
At the end of each use, check the status of the brushes **7** and clean or replace them, if necessary.



### **ELECTRICAL HAZARD!**

It is absolutely necessary to unplug and disconnect the appliance from the mains or battery before carrying out maintenance, replacement or cleaning operations.

---



### **CAUTION**

When the appliance is not being operating, use the support tripod **1** to prevent the brushes from warping while sitting on floor.

---



### **HAZARD!**

Do not use the appliance with worn or warped brushes. They can cause jerks or excessive vibration.  
Replace the brushes to avoid damaging the appliance.

---

### 7.2.1 Replacing the brushes

The appliance is fitted with a patented "trigger fitting" which enables the brushes to be removed and replaced in a few seconds.

In case of wearing, warping or simply for replacement of the brushes with brushes more suitable for the type of cleaning required, proceed as follows:

- 1) Remove the brushes 7 using the release device 9 (figure A).
- 2) Fit the new or optional brushes (figure B).

### 7.2.2 Cleaning the brushes

Check the status of the brushes 7, and if necessary, proceed as follows:

- 1) Remove the brushes 7 pressing the release device 9 (figure A).
- 2) Immerse them in a container of cold or lukewarm water and let them soak for a few hours.
- 3) Stir and rinse well.
- 4) Refit the brushes reversing their original position. This is necessary as the bristles tend to bend when the brushes always rotate in the same direction.

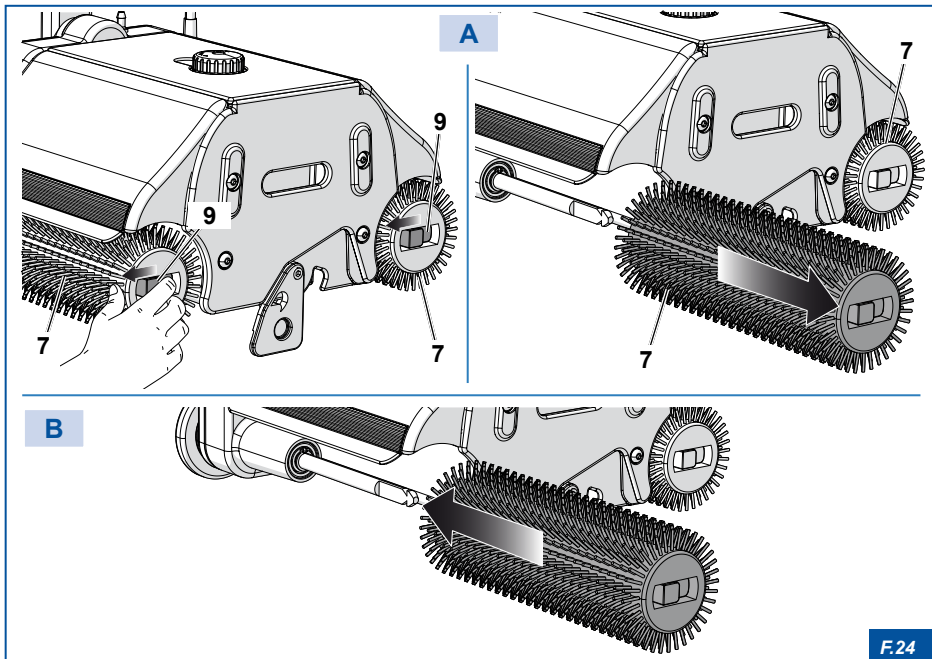

F.24

### 7.3 Replacing the scrapers

Keep the two recovery tank scrapers (11) clean at all times.

Replace them approximately every 150 work hours or when they are visibly worn.

To replace the scrapers 11, proceed as follows:

- 1) Remove the cover 4.
- 2) Remove the recovery tank 5.
- 3) Unscrew the screws 12 and remove the worn scrapers 11.
- 4) Replace the scrapers 4 and tighten the screws.

### 7.4 Conveyor belts

The conveyor belts 13 have an unlimited lifespan.



#### CAUTION

Do not use the appliance to collect sharp object that could cut through the rubber.

To always keep the belts 13 efficient, we recommend cleaning them periodically and lubricating them using silicone spray.

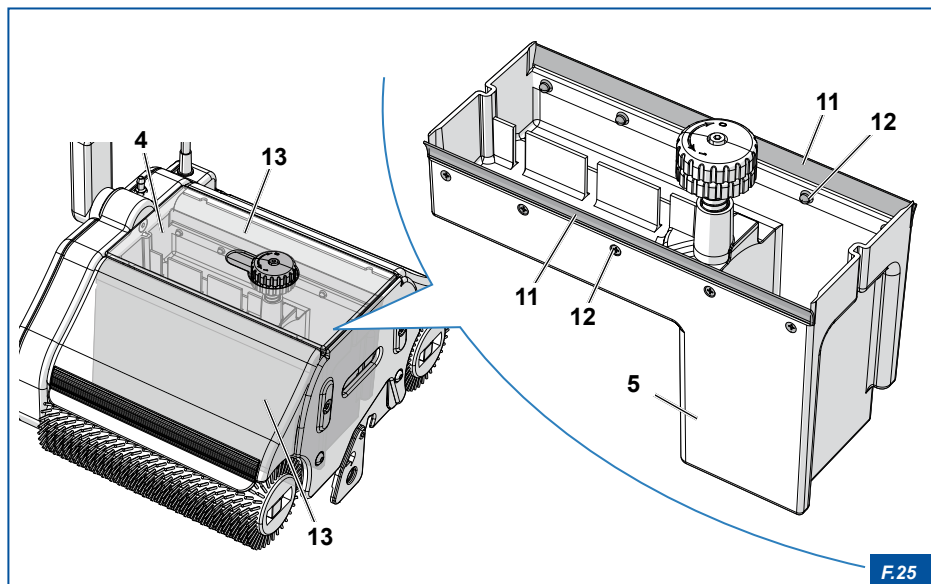

## 7.5 Power cord (DUPLEX 280i AC only)



**HAZARD!**

Cable replacement must be performed by qualified personnel.



**ELECTRICAL HAZARD!**

Do not use the appliance if the power cord or plug are damaged.

- Check the power cord regularly to see if there is any sign of damage: cracking, peeling, ageing.
- If the power cord is damaged, replace it before using the appliance.
- Use a cable of the same type used by the Manufacturer, certified according to “ENEC” European standards.
- If the power cord gets caught under the appliance brushes: STOP the appliance immediately. Do not try to remove the power cord for any reason while the appliance is running. If the power cord is damaged, replace it.

## 7.6 Routine maintenance table

OPERATION	INTERVENTION	FREQUENCY
<b>Cleaning</b>	Tank	After each use.
	Scrapers	After each use.
	Recovery tank	After each use.
	Appliance cleaning	After each use.
	Brushes	After each use.
<b>Checks</b>	Power cord. For the DUPLEX 280i AC only.	Before and during each use.
	Mechanical and drive elements	24 months / around 500 work hours.
<b>Replacement</b>	Scrapers	Around 150 work hours.
	Standard grey brushes	Around 250 work hours.

## 7.7 Disposal

### CAUTION



**Abusive disposal of the DUPLEX 280i by the user entails the application of penalties according to the regulations in force. Professional users, who decide to dispose of the DUPLEX 280i at the end of its lifespan and purchase a new equivalent machine with the same features, can agree upon the collection of the old DUPLEX 280i and delivery of the new machine.**

Pursuant to art. 13 of Legislative Decree of 25<sup>th</sup> July 2005, no. 151 “Fulfilment of the Directives 2002/95/EC, 2002/96/EC and 2003/108/EC on the restriction of the use of certain hazardous substances in electrical and electronic equipment and disposal of their waste”.

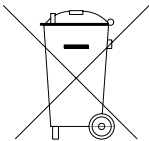

**The crossed-out bin symbol on the equipment indicates that at the end of its lifespan, the product, must be collected separately from other waste.**

**The user must deliver the appliance, at the end of its lifespan, to an appropriate collection point for the recycling of electric and electronic equipment or deliver it back to the retailer when purchasing a new equivalent appliance on a one-to-one basis.**

**Correct disposal of the DUPLEX 280i for its recycling, treatment and environmentally sustainable disposal will help prevent potential negative consequences for the environment and human health, and will help recycle the materials of which the appliance consists.**

### 7.7.1 Differentiation and sorting of the materials

#### **Electrical components:**

Material that can be disposed of with the urban waste collection, in compliance with the legal provisions in force in the country of use.

#### **Mechanical components:**

The appliance is built with aluminium, steel and plastic materials.

Steel and aluminium will not damage the environment if recycled by qualified and authorised companies.

The plastic materials may cause environmental damage, therefore they should be handed over to specialised companies authorised for disposal.

The disposal of the packaging must be carried out in accordance with the regulations in force.

### 7.7.2 Disposing of the battery (DUPLEX 280i DC only)

The **DUPLEX 280i DC** is equipped with a lithium ion battery inserted in an appropriate fireproof plastic enclosure, hermetically closed and easy to remove from the appliance by simply unscrewing a knob manually.

The battery, at the end of its lifespan, must be disposed of separately from other waste.

---

#### HAZARD!



**Do not burn lithium batteries as they could explode or blow up violently. Carefully collect the batteries for disposal. Avoid them being short-circuited or their enclosure being compacted or destroyed.**

**Check and follow all local, regional and national laws on the disposal of these materials. The user is legally responsible for hazards generated during the disposal of batteries and preservation of material resources which enable the recovery of valuable materials.**

---

## 8. TROUBLESHOOTING

The maintenance interventions authorised by **Duplex International S.r.l.** are indicated in chapter [“7. MAINTENANCE”](#).

The content of this chapter is not exhaustive. Instead, it aims to provide information on the most common problems in order to help specialised technicians to find the fault in question.



### CAUTION

The indications under the term **“SOLUTION”** in the tables below **DO NOT AUTHORISE** interventions that could jeopardise safety.

PROBLEMS	PROBABLE CAUSE	SOLUTION
Wet stripes on the sides	Excessive liquid dispensed.	Dispense less liquid.
	Irregular paths are covered.	Follow the instructions in chapter <a href="#">“7. MAINTENANCE”</a> .
	Recovery tank in raised position <b>“1”</b> .	Turn the knob to <b>“0”</b> .
	Recovery tank scrapers dirty or worn out.	Clean or replace the scrapers.

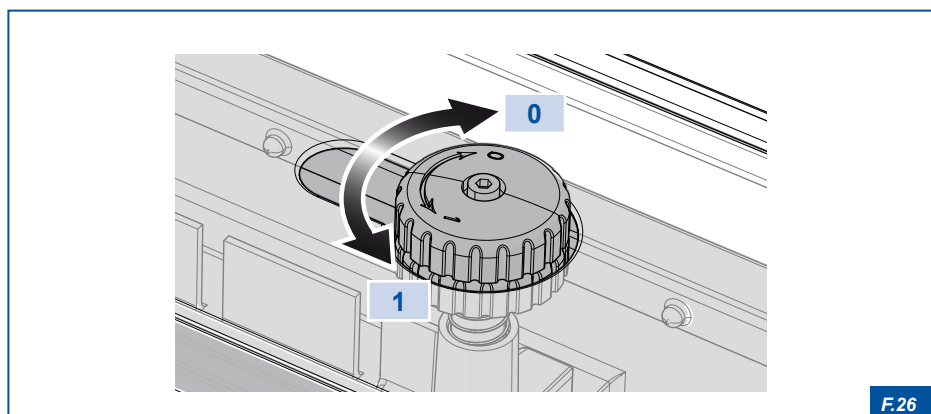

F.26

<b>Liquid flows continuously</b>	The valve in the tank remained open because the clamp screw under the handle lever has slid or moved.	Loosen the screw and adjust.
	Foreign bodies inside the valve.	Disassemble and clean.
	Valve rubber seal worn.	Replace.
<b>The dirt is not picked up</b>	Recovery tank raised “1” or not properly inserted into its housing.	Turn the knob to “0”. Check for the correct positioning of the recovery tank. (See section “6.1.2 Recovery tank”).
	Recovery tank with dirty or worn scrapers.	Clean or replace.
	Worn brushes.	Replace.
	Cleaning liquid not coming out.	Check the valve and adjust the screw under the handle lever.
<b>Does not start up</b>	Sometimes the appliance does not start given the strong friction of the brushes.	Lift slightly by tilting the handle.
	Scrapers left resting on and stuck to the conveyor belts by the dry residual dirt deposited from the previous cleaning operation.	Turn the knob to (1) to raise the recovery tank and detach it from the conveyors. Clean and then start up and return the knob to “0” (see section “6.1.2 Recovery tank”).
	“Motor Protector” tripped	Reset the appliance and reactivate it by pressing the <b>MP</b> button on the handle. Reactivation occurs approx. after 2 minutes.
	Faulty motor.	Contact the Manufacturer.
	“Start&stop” button switch tripped.	Replace.

<b>Does not start up DUPLEX 280i AC</b>	Power cord faulty or plug not correctly inserted into the socket.	Restore and replace, if necessary.
	Power cord tripped.	Replace.
	Voltage too low.	Contact the mains provider.
	Start-up capacitor tripped or in short circuit.	Replace.
<b>Does not start up DUPLEX 280i DC</b>	Battery fuse tripped.	Remove the fuse cap on the battery and replace with an identical one of 15 Amp. Do not use fuses exceeding 15 Amp to avoid serious risks. If the fuse trips again, search for the fault on the appliance.
	Power cord plug not correctly inserted into the battery.	Restore.
	Flat battery.	Re-charge or replace with a fully charged spare battery.
<b>Vibrations during the work stages</b>	Warped brushes.	Replace.



**WB FLOOR  
MACHINES**  
SALES · SERVICE · HIRE

☎ 01293 852022

✉ info@wbfloormachines.co.uk

🌐 www.wbfloormachines.co.uk

🏠 Unit 7 Burns Way, Holmbush Potteries  
Estate, Horsham RH12 4ST